

# Agglomerati

Between a Rock and  
a Hard Place

Designed by Maria Tyakina



# BARAAHP

Between a Rock and a Hard Place (BARAAHP) is a collection that strikes a balance between fluid and solid forms, with each object taking on a bodily quality reminiscent of human gestures and postures.

The pieces express the complexities and subtleties of the human experience, combining function and expression in a sculptural and physical manner.

Previously produced in wood, these original iterations comprising a console, shelf, and two side tables, have been created using reclaimed Rosso Aurora marble.

Originally from the quarries of Estremoz, Portugal, the marble, which had lain dormant for 40 years, is sourced through a sustainability project by Leleni Studio, who are repurposing over 2000m<sup>2</sup> of marble from a famous retired Catalan stonemason.

# Agglomerati

BARAAHP

Designed by Maria Tyakina



[01]

Console  
Rosso Aurora

W	L	H	
120.5	30	81	cm
47.4	11.8	31.8	in

120.5



81



30

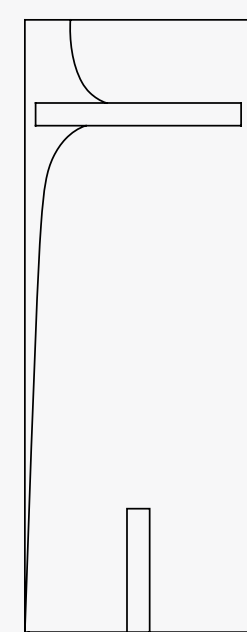

Agglomerati



BARAAHP

[03]

Shelf  
Rosso Aurora

W	L	H	
59	32	64	cm
23.2	12.6	25.2	in

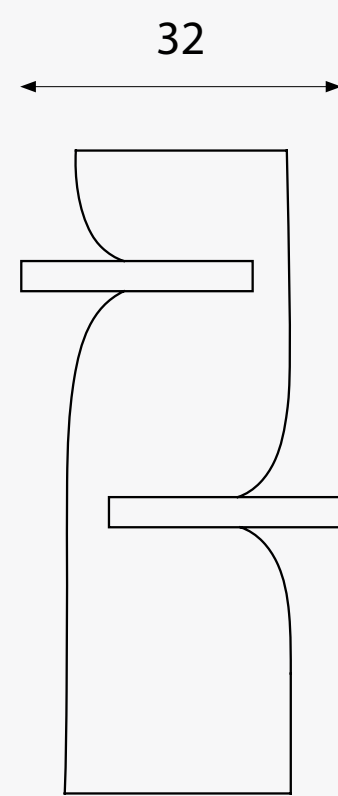
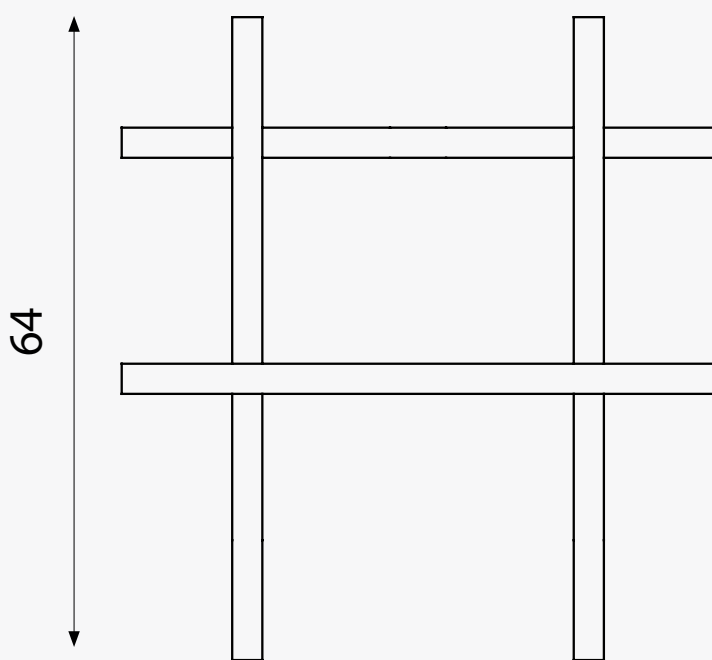
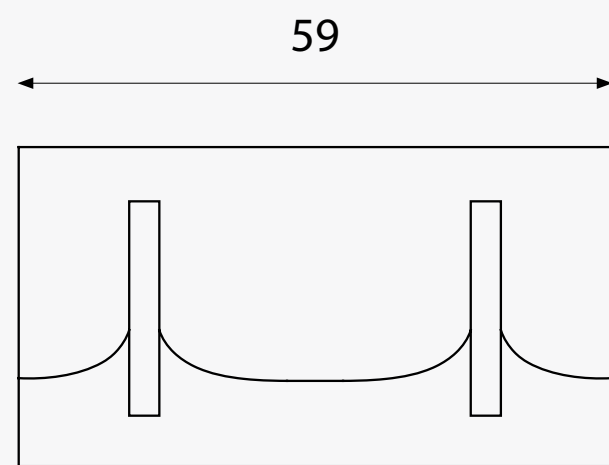

Agglomerati



BARAAHP

[02]

Side Table  
Rosso Aurora

W	L	H	
43.5	41	51	cm
17.1	16.1	20.1	in

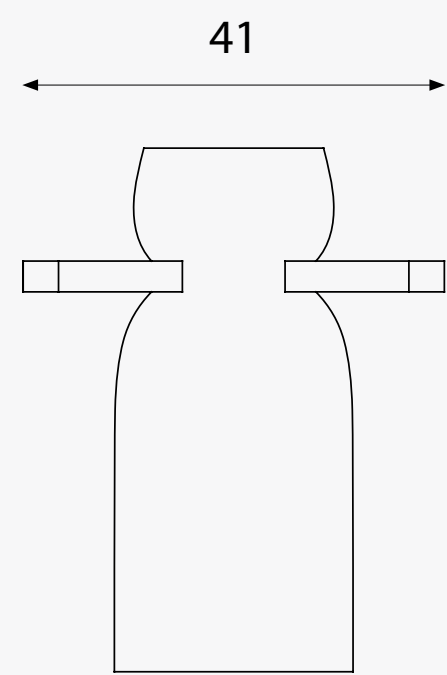
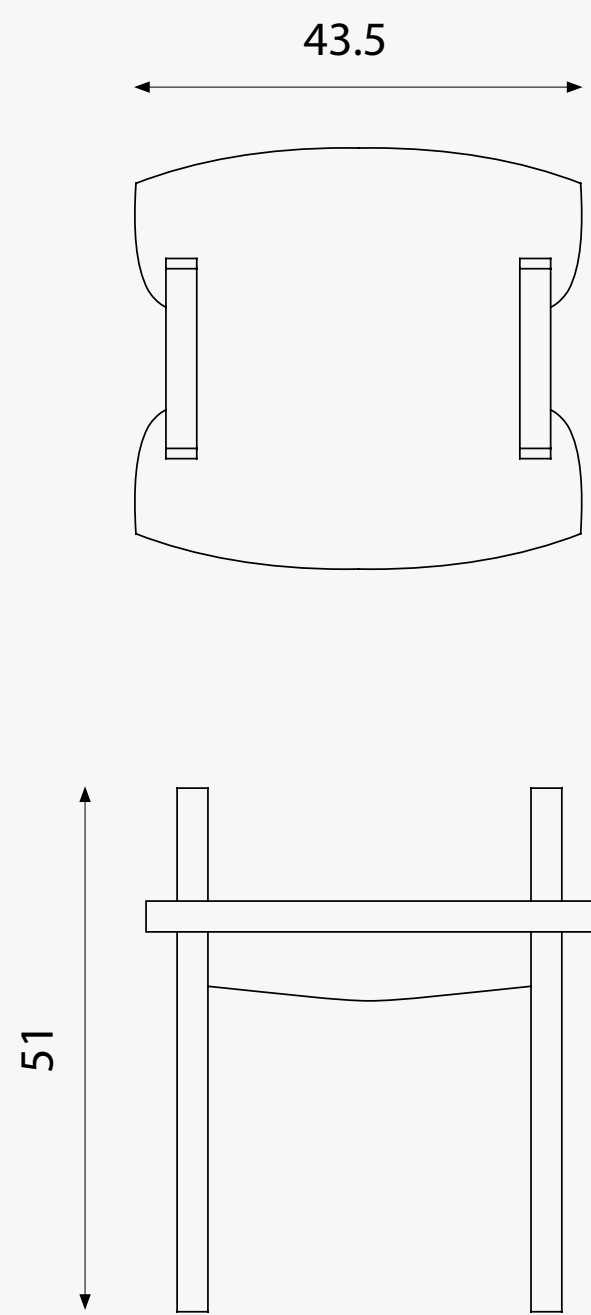

Agglomerati



BARAHP

# Agglomerati

## Maria Tyakina

Maria Tyakina is a product designer and furniture designer whose artistic practice centres around exploring physicality and reimagining the habitual ways of viewing everyday objects. Sculptural gestures characterise Maria's work and emphasise form, materiality, and spatial relationships. She is interested in exploring the relationship between humans and objects to understand the ways that objects mediate our connection to the physical world.

Through her design language, Maria aims to blend form and narrative with the inherent qualities of the materials and construction techniques used.

Originally from Russia, Maria completed her Interior Architecture and Furniture Design studies at the Royal Academy of Art in The Hague, in the Netherlands, where she now lives and works.

## Objects of Permanence

Agglomerati collaborates with multidisciplinary designers to create functional art-objects in stone.

Founded by Sam Henley, the studio connects a diverse network of creatives with northern Italy's foremost craftspeople, offering fresh perspectives on a time-honored material. The resulting bespoke objects are produced in collectible editions, adding a new material dimension to the collaborating artist's body of work. Each piece is crafted by Agglomerati's network of established

practitioners, using the finest materials and finished to the highest standards.

Translated from Italian, Agglomerati means "to mass together" or "a collection of things." This refers to the composition of minerals that, when placed under pressure over time, react to form stone. It also reflects the studio's evolving collective of creatives—individuals who come together to produce works made exclusively in stone.



Agglomerati



BARAHP





# Agglomerati

## Contact

E [info@agglomerati.com](mailto:info@agglomerati.com)

T 0044 7513 703391

W [agglomerati.com](http://agglomerati.com)

IG [@agglomerati](https://www.instagram.com/agglomerati)