

# Agglomerati

**Mass**

Designed by Fred Ganim

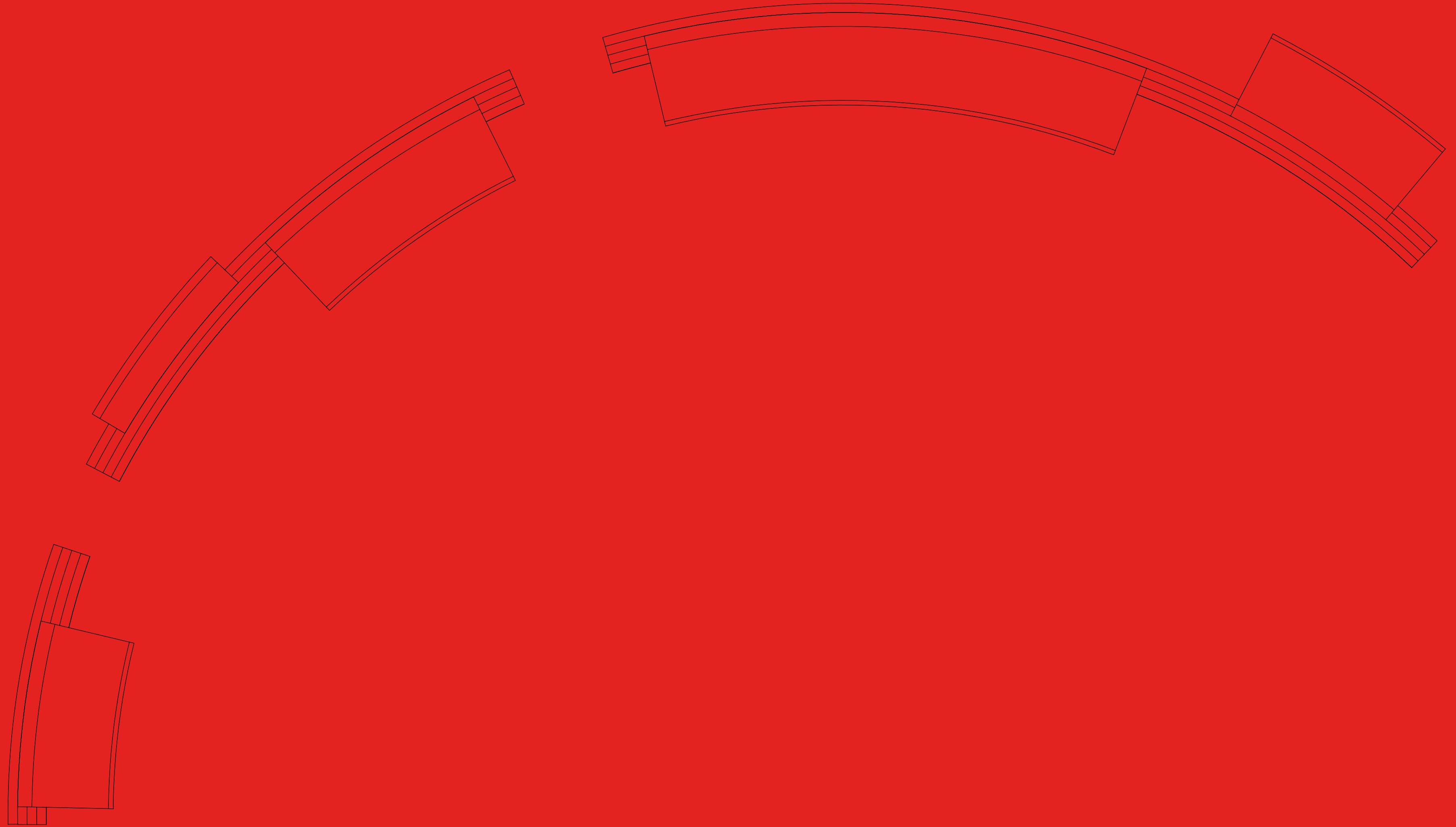

# Mass

Upon its extraction from the earth, marble is cut into large cubic volumes. MASS explores the reduction of these volumes, subverting the material's inherent behaviours.

Grounded by its weight, the sheer mass of the material uses gravity as a structural force, cantilevering a system of moveable shelves so that they appear to float parallel to the ground. Each piece is available in several different sizes, slotting together to serve as lecterns, shelves or tables.

In its original iteration, the collection is produced in Palissandro marble, sourced in one of northern Italy's foremost quarries, located in Domodossola, North of Milano. MASS is an open series that can be produced in several different sizes and a selection of other Italian marbles.

# Agglomerati

Mass

Designed by Fred Ganim



# [01]

Mass: small

Config A:  
BS-90  
SIC-60

L	W	H
93	36	80
36.6	14.2	31.5

93

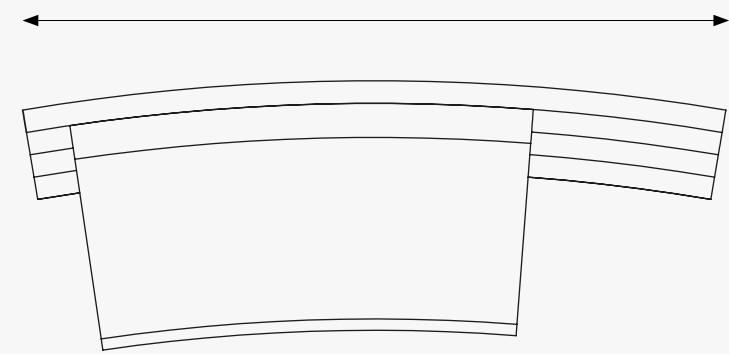

36

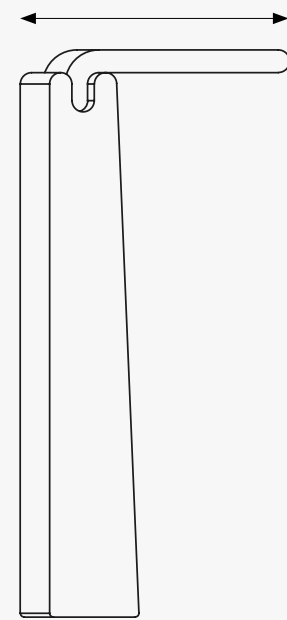

80



Agglomerati



Mass

# [01]

Mass: small

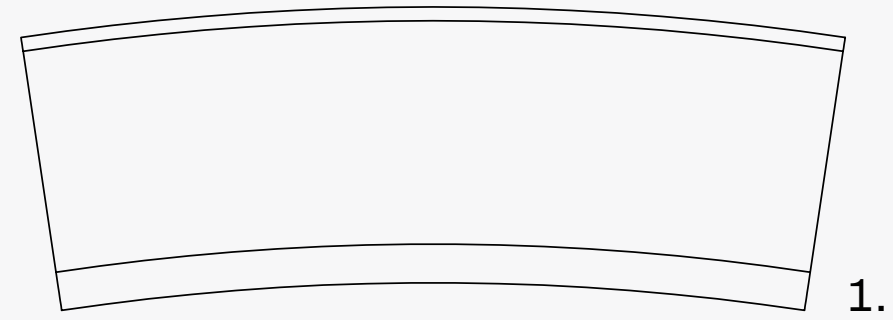

1.

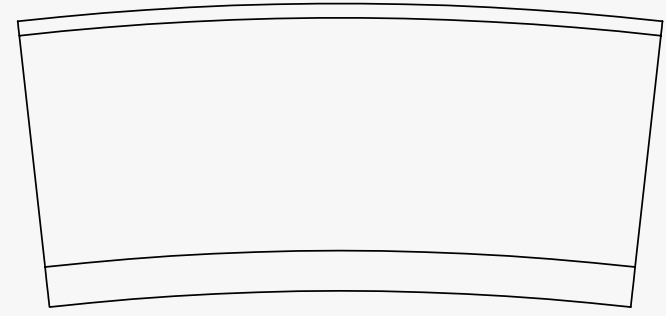

2.

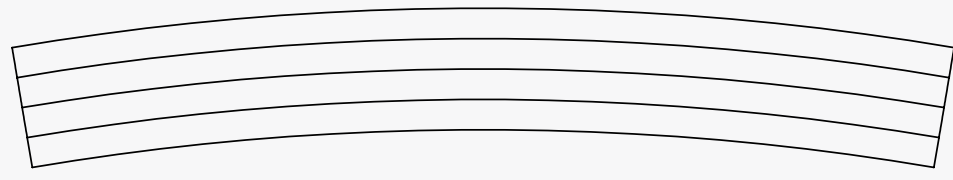

3.



4.

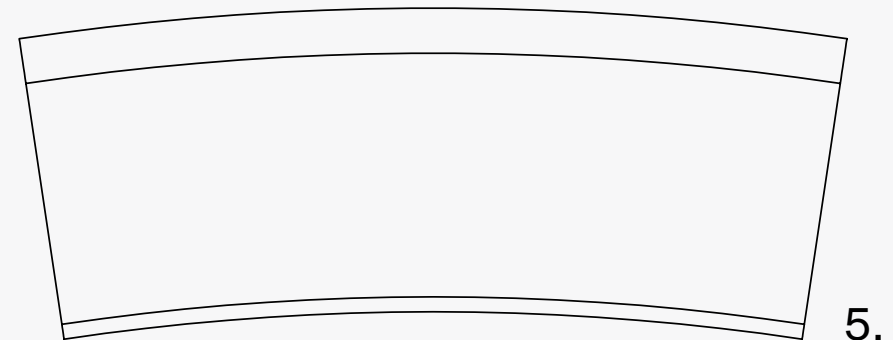

5.

- 1. SOC-80
- 2. SOC-60
- 3. Base
- 4. SIC-60
- 5. SIC-80

Agglomerati

## Modular Elements

			Code	L	W	H
Base	Smal, Short (BS)		BS-90	93	12.8	37
			BT-90	93	12.8	77
Shelf	Outer Curve (SOC)		SOC-60	60	30	3
			SOC-80	80	30	3
	Angle Curve (SAC)		SAC-60	60	30	27.4
			SAC-80	80	30	27.4
	Inner Curve (SIC)		SIC-60	60	30	3
			SIC-80	80	30	3

Mass

# [02]

Mass: medium

Config B:  
BS-180  
SAC-60  
SIC-80

L	W	H
186	26.7	40
73.2	29.9	15.7

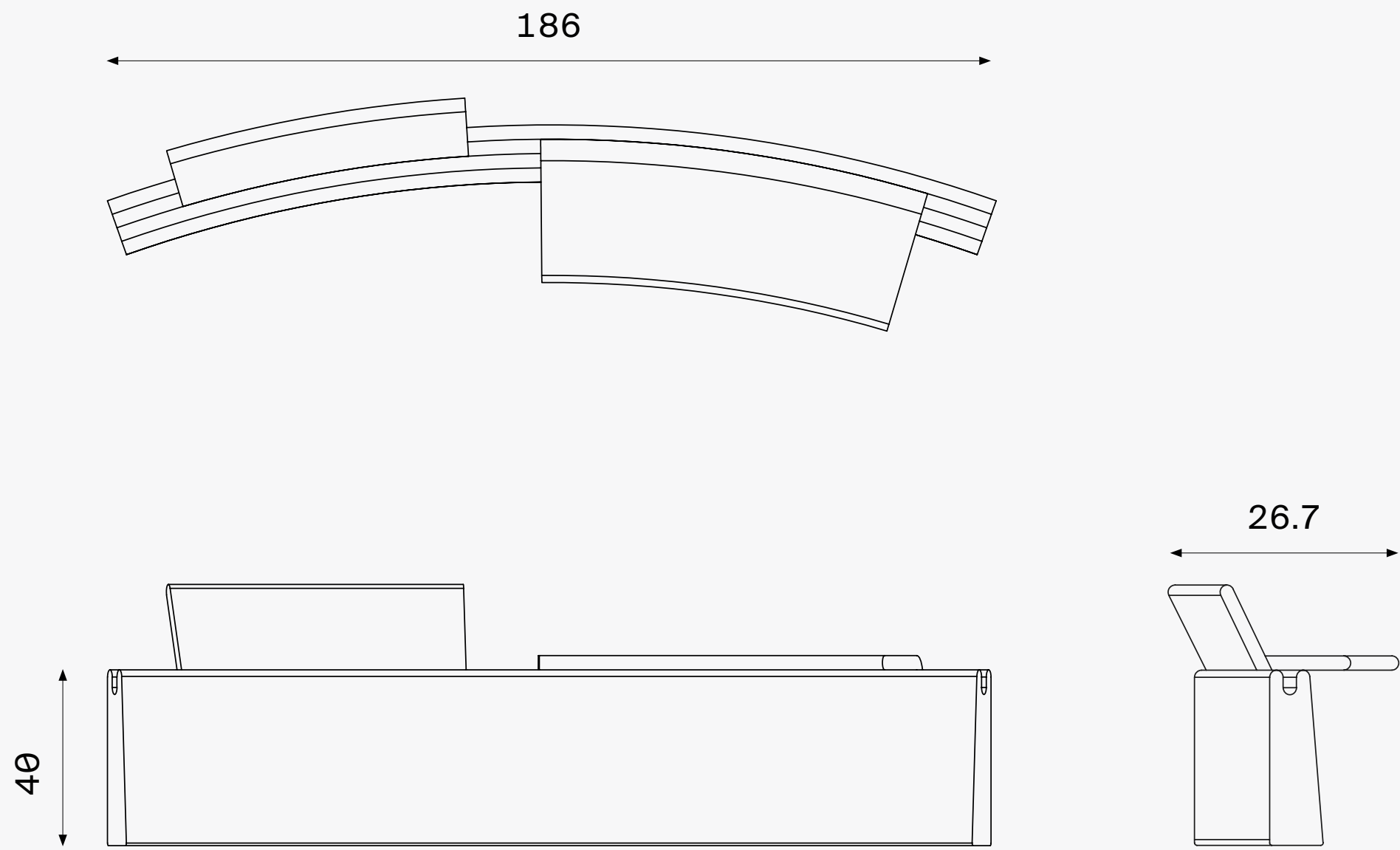

Agglomerati



Mass

# [02]

Mass: medium

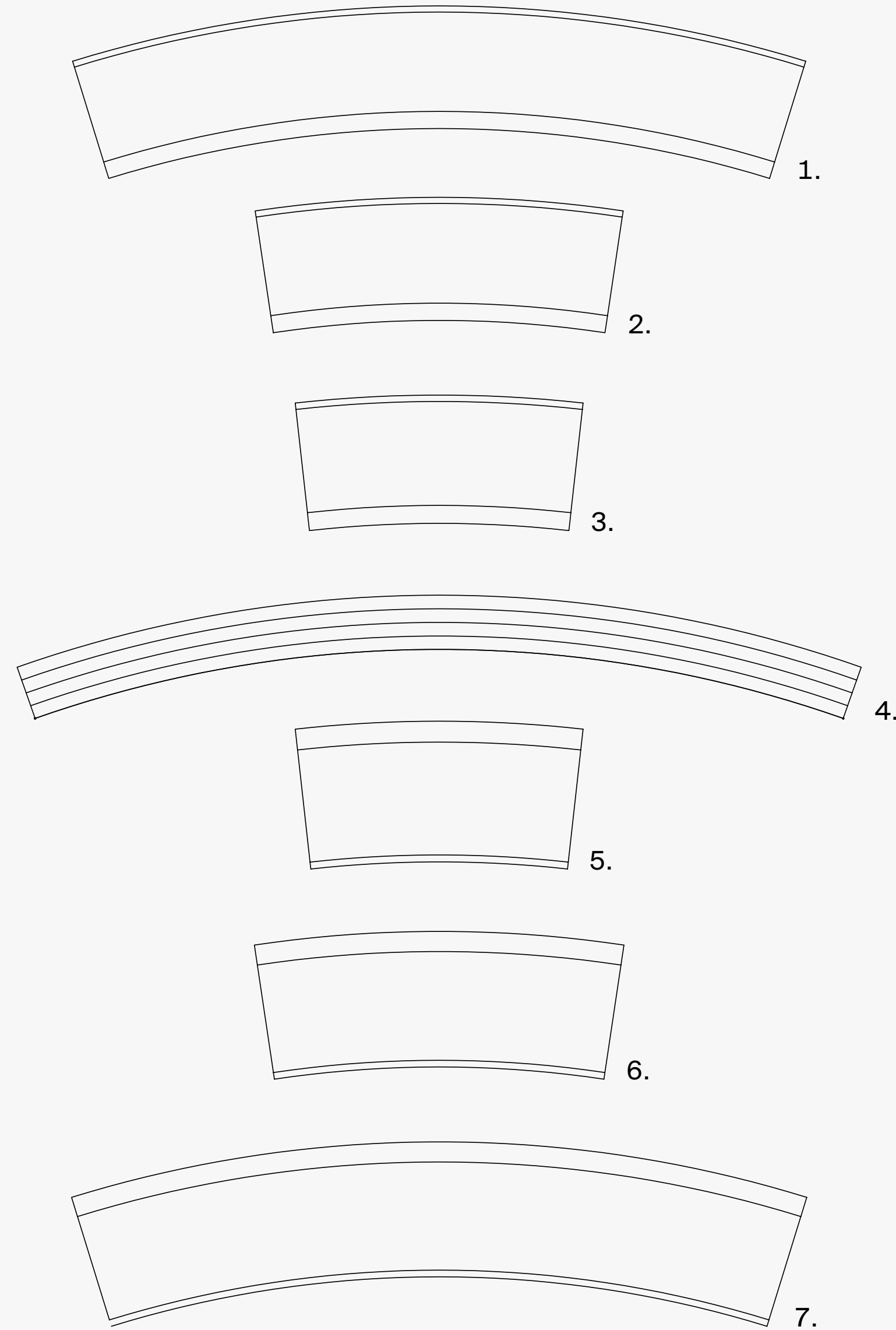

- 1. SOC-160
- 2. SOC-80
- 3. SOC-60
- 4. Base
- 5. SIC-60
- 6. SIC-80
- 7. SIC-160

Agglomerati

## Modular Elements

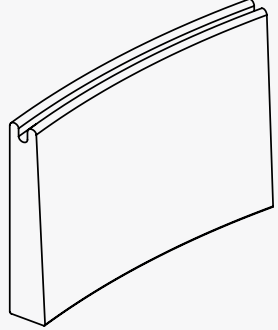
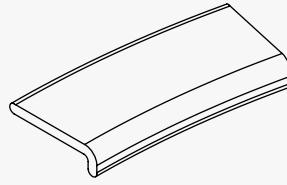
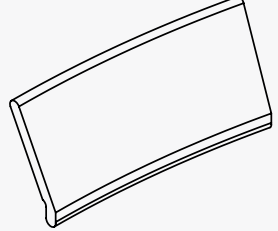
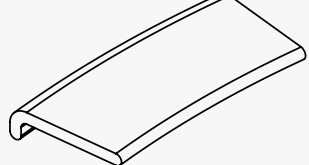
		Code	L	W	H	
Base	Medium, Small (BS)		BS-180	186	26.5	37
			BT-180	186	26.5	77
Shelf	Outer Curve (SOC)		SOC-60	60	30	3
			SOC-80	80	30	3
			SOC-160	160	30	3
	Angle Curve (SAC)		SAC-60	60	30	27.4
			SAC-80	80	30	27.4
			SAC-160	160	30	27.4
	Inner Curve (SIC)		SIC-60	60	30	3
			SIC-80	80	30	3
			SIC-160	160	30	3

Mass

# [03]

Mass: large

Config B:  
BS-180  
SOC-60  
SIC-160

L	W	H	
279	47.6	80	cm
109.8	29.9	31.5	in

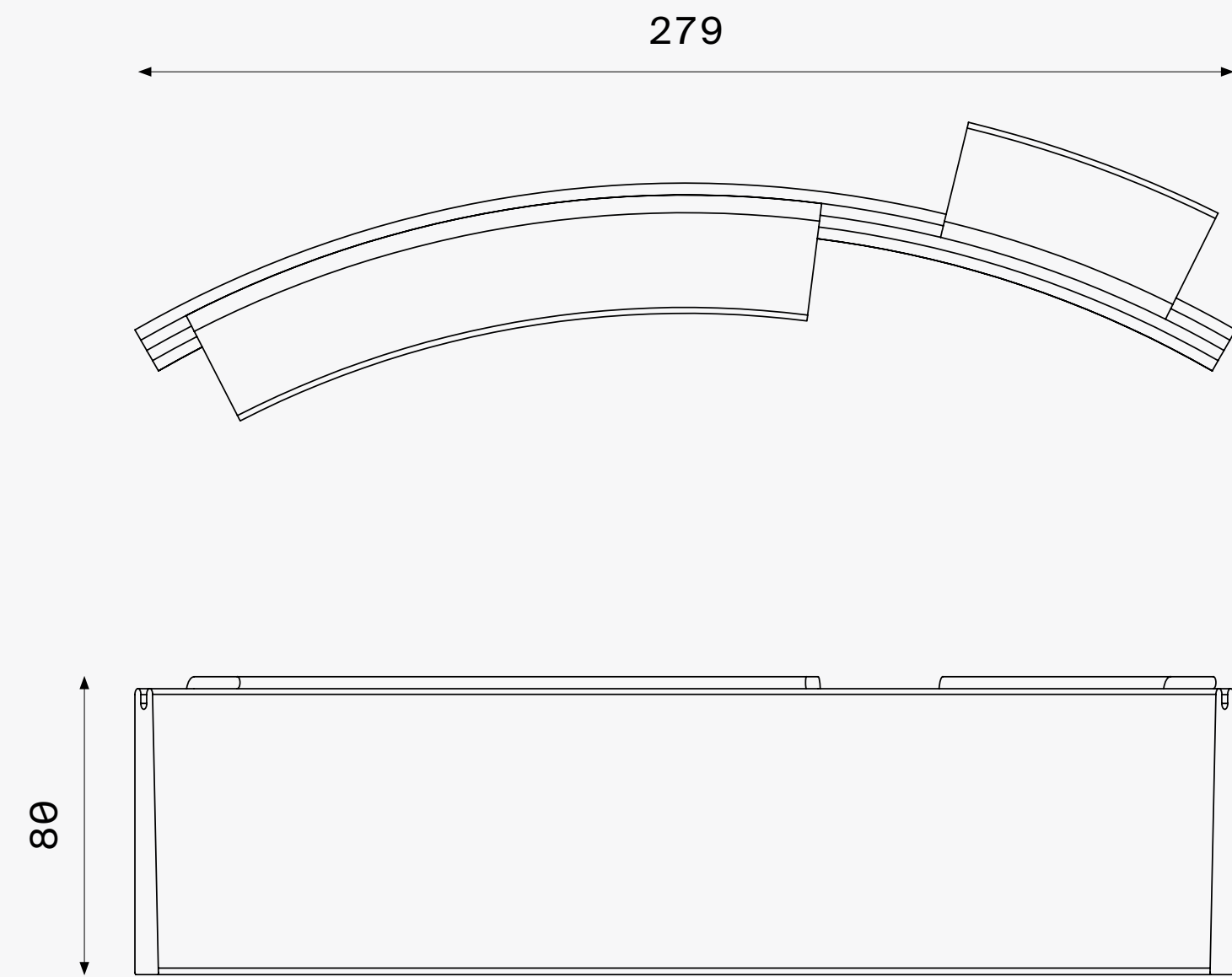

Agglomerati

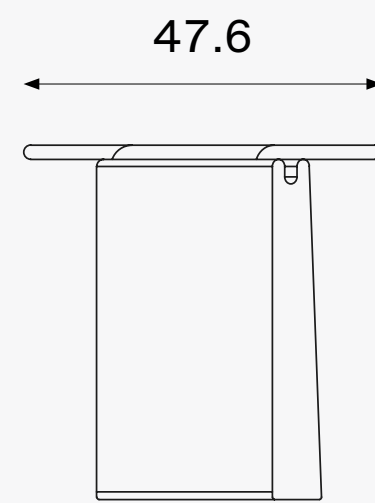

Mass



# [03]

Mass: large

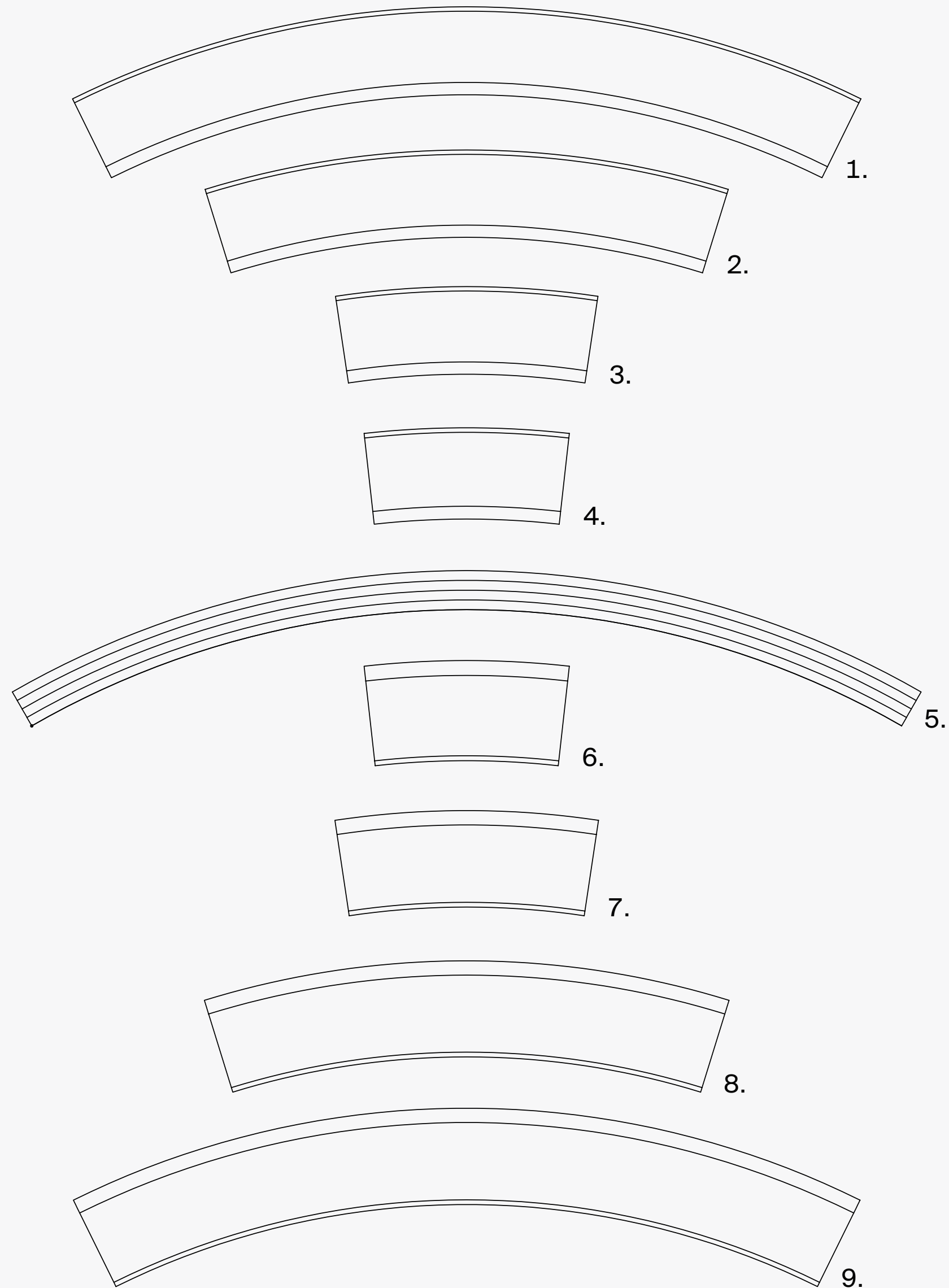

- 1. SOC-240
- 2. SOC-160
- 3. SOC-80
- 4. SOC-60
- 5. Large Base
- 6. SIC-60
- 7. SIC-80
- 8. SIC-160
- 9. SIC-240

Agglomerati

## Modular Elements

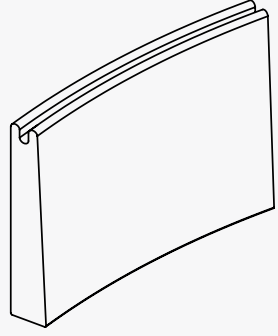
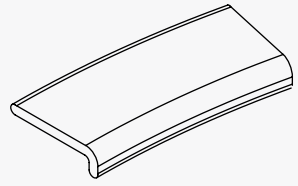
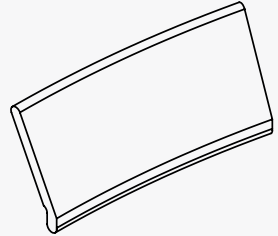
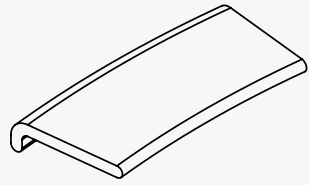
			Code	L	W	H
Base	Large, Small (BS)		BS-270	279	47.5	37
			BT-270	279	47.5	77
Shelf	Outer Curve (SOC)		SOC-60	60	30	3
			SOC-80	80	30	3
			SOC-160	160	30	3
			SOC-240	240	30	3
	Angle Curve (SAC)		SAC-60	60	30	27.4
			SAC-80	80	30	27.4
			SAC-160	160	30	27.4
			SAC-240	240	30	27.4
	Inner Curve (SIC)		SIC-60	60	30	3
			SIC-80	80	30	3
SIC-160			160	30	3	
SIC-240			240	30	3	

Mass

# Agglomerati

## Fred Ganim

Fred Ganim is a furniture maker who lives and works in Melbourne, Australia. His practice is intuitive and process-driven; clean lines and carefully constructed joints emerge in a contemporary collision of traditional artisanal techniques and modern, forward-thinking ideas.

Joinery, in particular, is a focus of his work. Individual elements appear to flow seamlessly from and into one another, opposing forces meeting and finding equilibrium in the arm of a chair, or the leg of a table.

The results are practical pieces, created with a nuanced but playful approach. Transposed from timber to stone, Ganim's signature joint is thrust to the forefront of his creations. Marble flows fluidly through grooves, curves and cantilevers, exuding a tactility and sense of ceremony that resonates through a room.

MASS is his first collection of works in stone.

## Objects of Permanence

Agglomerati collaborates with multidisciplinary designers to create functional art-objects in stone.

Founded by Sam Henley, the studio connects a diverse network of creatives with northern Italy's foremost craftspeople, offering fresh perspectives on a time-honored material. The resulting bespoke objects are produced in collectible editions and open series, adding a new material dimension to the collaborating designer's body of work. Each piece is crafted by Agglomerati's network

of established practitioners, using the finest materials and finished to the highest standards.

Translated from Italian, Agglomerati means "to mass together" or "a collection of things." This refers to the composition of minerals that, when placed under pressure over time, react to form stone. It also reflects the studio's evolving collective of creatives—individuals who come together to produce works made exclusively in stone.



Agglomerati



Mass

# Agglomerati

## Contact

E [info@agglomerati.com](mailto:info@agglomerati.com)

T 0044 7513 703391

W [agglomerati.com](http://agglomerati.com)

IG [@agglomerati](https://www.instagram.com/agglomerati)