

Agglomerati

Round Table

Designed by Fred Ganim

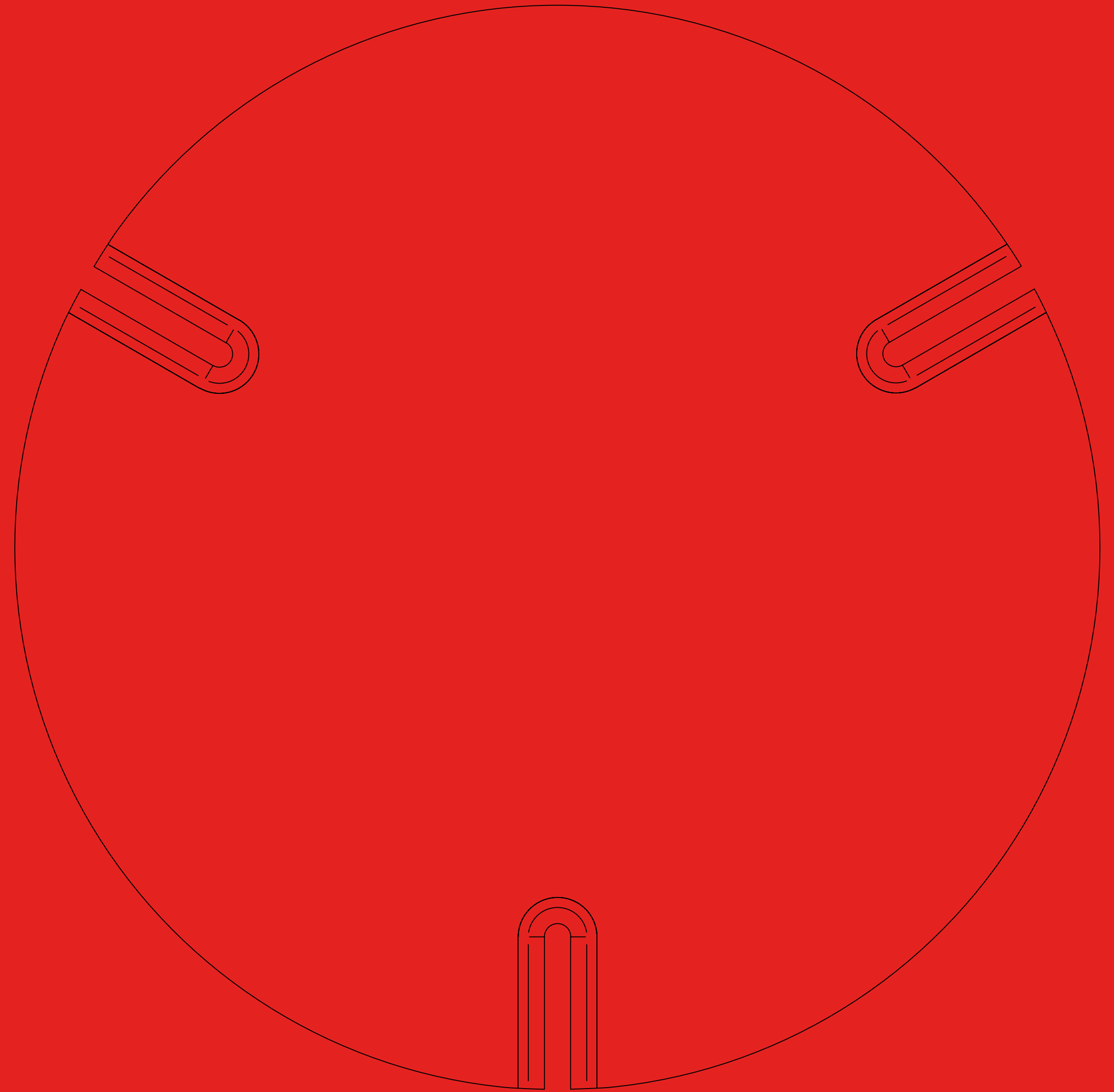

Round Table

Based on Ganim's original Round Table in wood, this exceptional piece is carved from a single block of stone. The stone's intricate textures and layered tones emerge in tightly compressed strata across the table's smooth surface, cascading seamlessly down the legs, each formed in a fluid, folded curve.

Agglomerati

Round Table

Designed by Fred Ganim



[011]

Round Table 117
Pictured in Brazilian Qartzite

W	H
117	30 cm
46	11.8 in

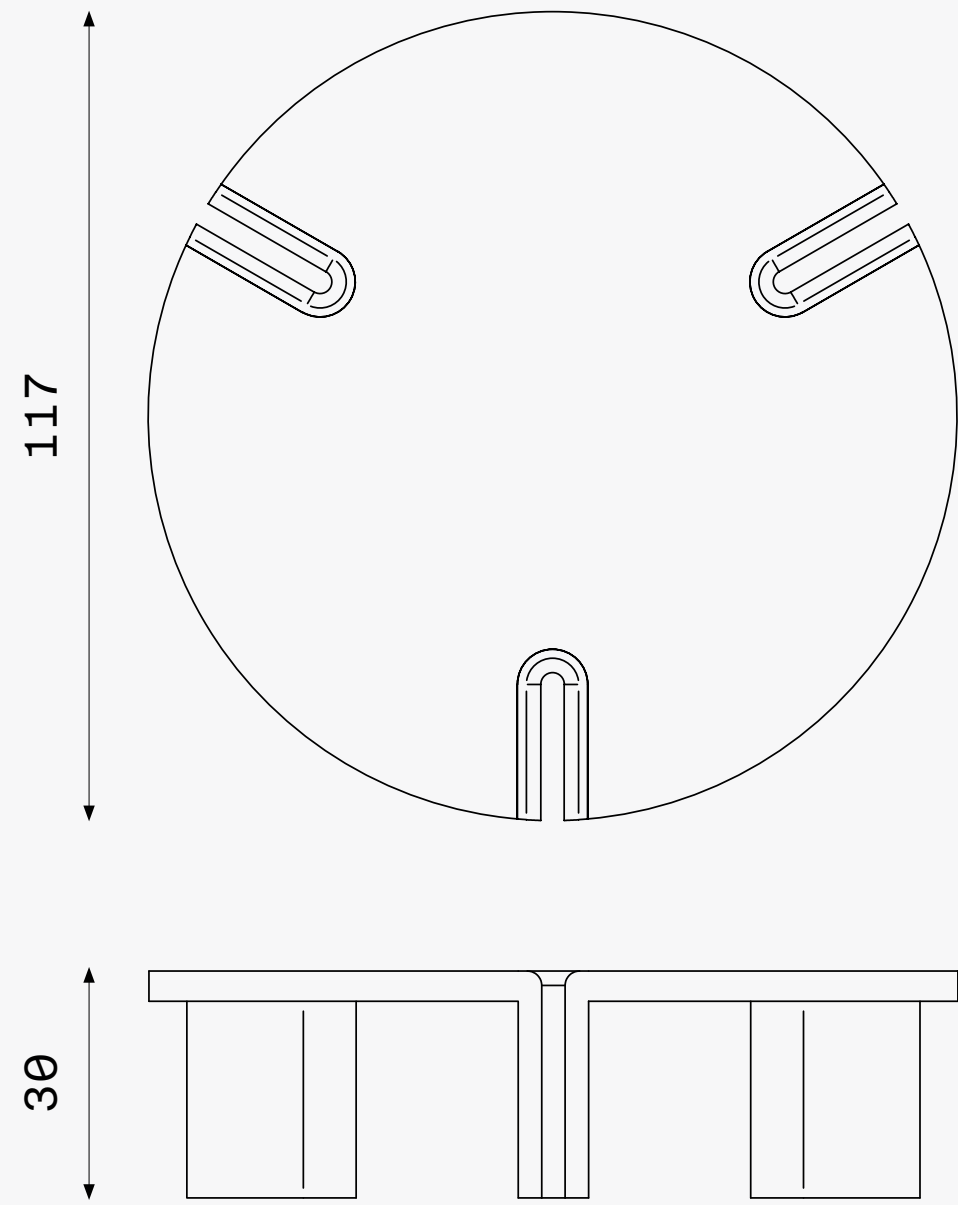

Agglomerati



Round Table (Brazilian Quartzite)

Round Table

Designer: Fred Ganim
 Production: Open Series
 Typical lead time: 8 Weeks
 Made in Italy

Round Table can be commissioned in various stone types and custom dimensions. Please refer to our website for additional material options.

Materials



Brazilian Quartzite



Calacatta Oro

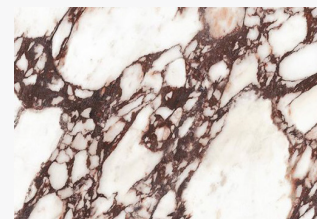

Calacatta Viola



Arabescato

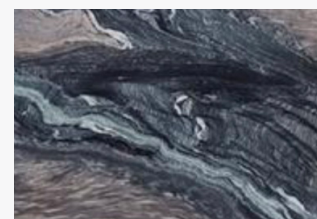

Cipollino Dark

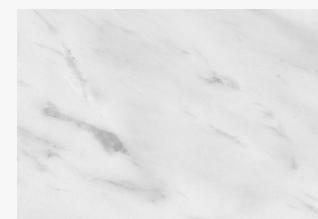

Bianco Carrara

Agglomerati

[01] Round Table 140

W H
 140 30 cm
 55.1 11.8 in

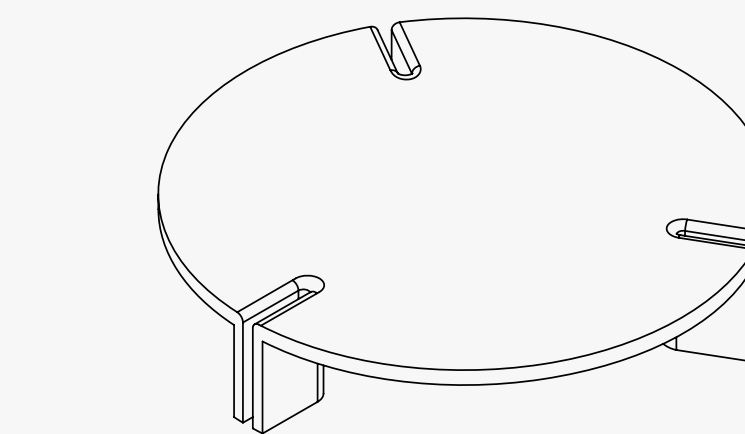
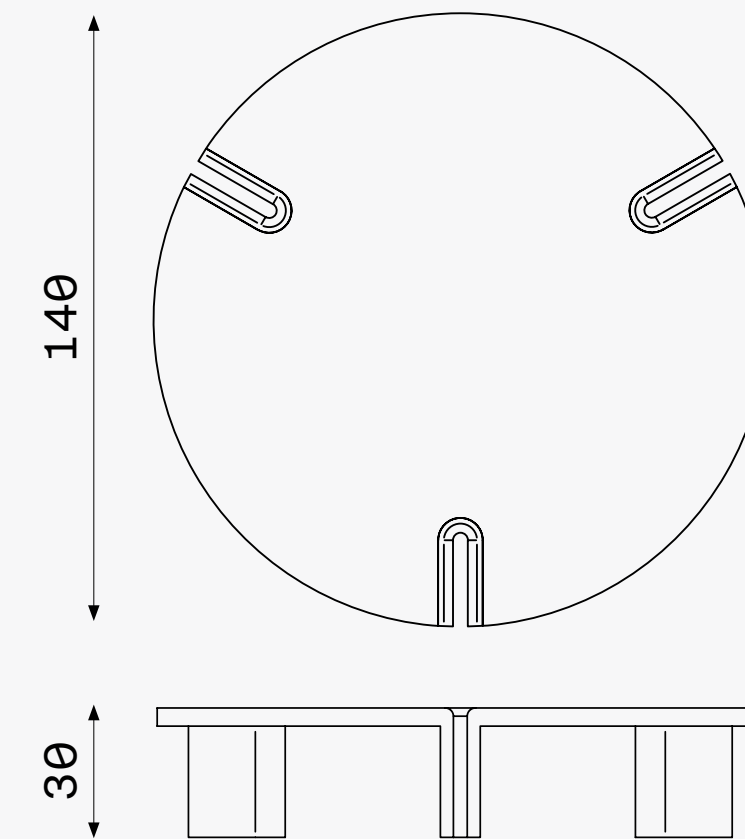

Round Table

[02] Round Table 117

W H
 117 30 cm
 46 11.8 in

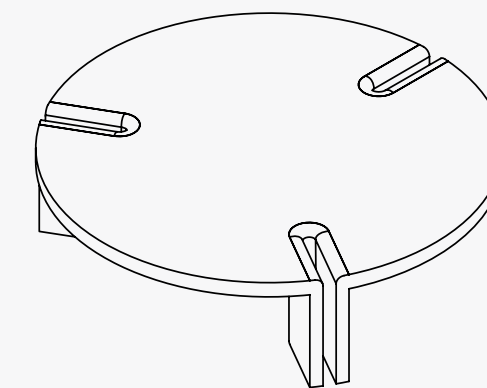
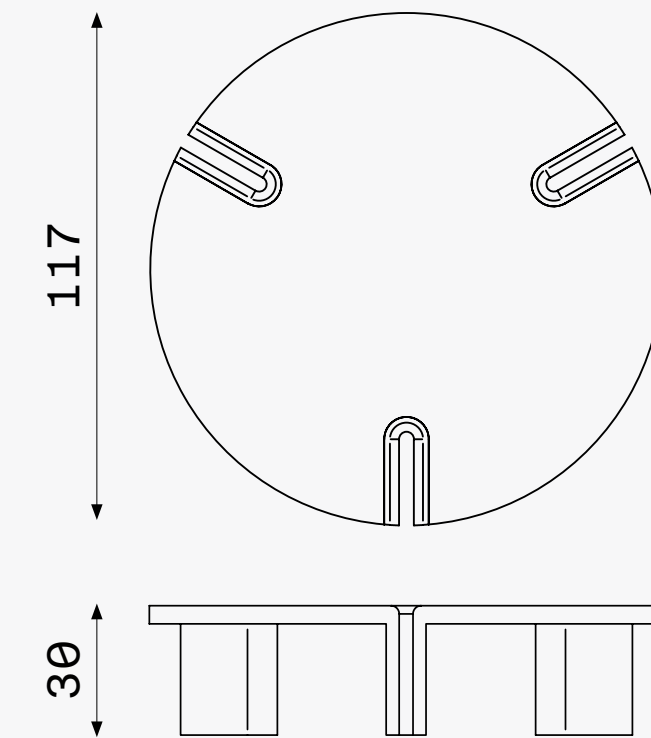

[03] Round Table 78

W H
 78 30 cm
 30.7 11.8 in

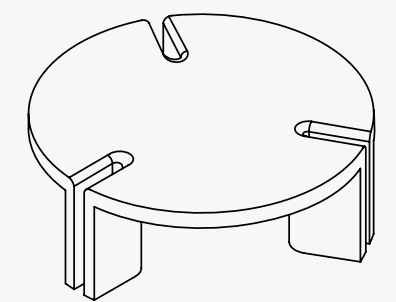
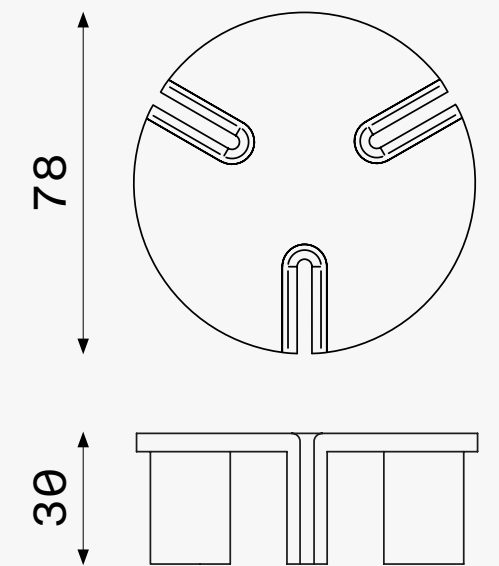

Agglomerati

Fred Ganim

Fred Ganim is a furniture maker who lives and works in Melbourne, Australia. His practice is intuitive and process-driven; clean lines and carefully constructed joints emerge in a contemporary collision of traditional artisanal techniques and modern, forward-thinking ideas.

Joinery, in particular, is a focus of his work. Individual elements appear to flow seamlessly from and into one another, opposing forces

meeting and finding equilibrium in the arm of a chair, or the leg of a table.

The results are practical pieces, created with a nuanced but playful approach. Marble flows fluidly through grooves, curves and cantilevers, exuding a tactility and sense of ceremony that resonates through a room.

Objects of Permanence

Agglomerati collaborates with multidisciplinary designers to create functional art-objects in stone.

Founded by Sam Henley, the studio connects a diverse network of creatives with northern Italy's foremost craftspeople, offering fresh perspectives on a time-honored material. The resulting bespoke objects are produced in collectible editions, adding a new material dimension to the collaborating artist's body of work. Each piece is crafted by Agglomerati's network of established

practitioners, using the finest materials and finished to the highest standards.

Translated from Italian, Agglomerati means "to mass together" or "a collection of things." This refers to the composition of minerals that, when placed under pressure over time, react to form stone. It also reflects the studio's evolving collective of creatives—individuals who come together to produce works made exclusively in stone.



Agglomerati



Round Table

Agglomerati

Contact

E info@agglomerati.com

T 0044 7513 703391

W agglomerati.com

IG [@agglomerati](https://www.instagram.com/agglomerati)