

Agglomerati

Surfaced

Designed by Sho Ota

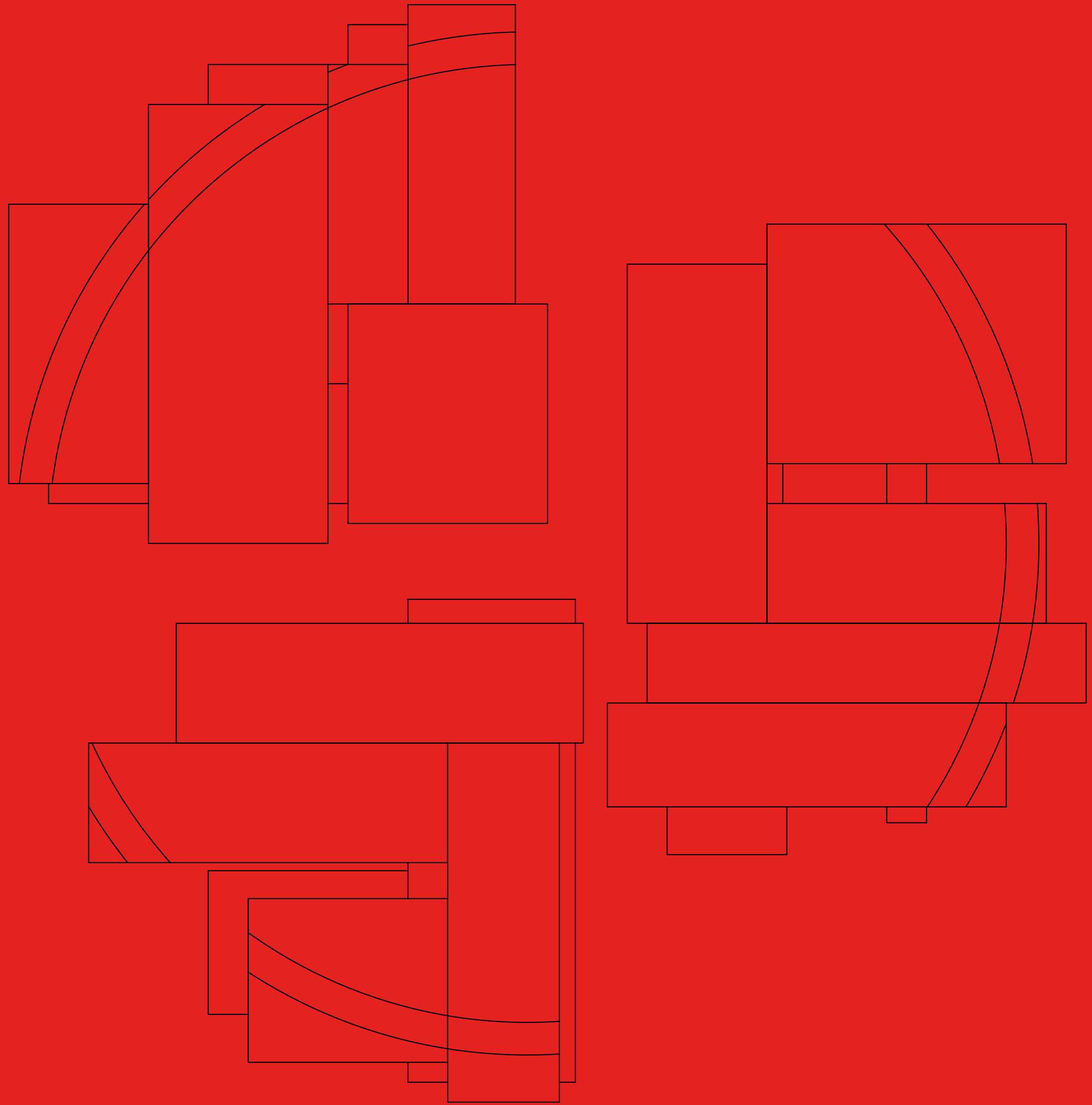

Surfaced

Built from an assembly of cubic elements varying in size, The 'Surfaced' series plays with empty and solid forms to convey presence through light reflection.

Inspired by Northern Japan's traditional "boro" clothing, this iteration of 'Surfaced' merges individual parts into a unified whole, emphasizing unity and purpose. The Surfaced bench marks the first iteration in a new series of limited edition crea-

tions by Sho Ota, which already includes a side table and coffee table. Utilizing stone as the primary medium, this new direction offers the designer a fresh platform to explore innovative gestures and considerations within this material.

Agglomerati

Surfaced



Designed by Sho Ota

[01]

Surfaced:
Bench
Bianco Carrara

W L H
165 46 40 cm
65 18.1 15.7 in

165

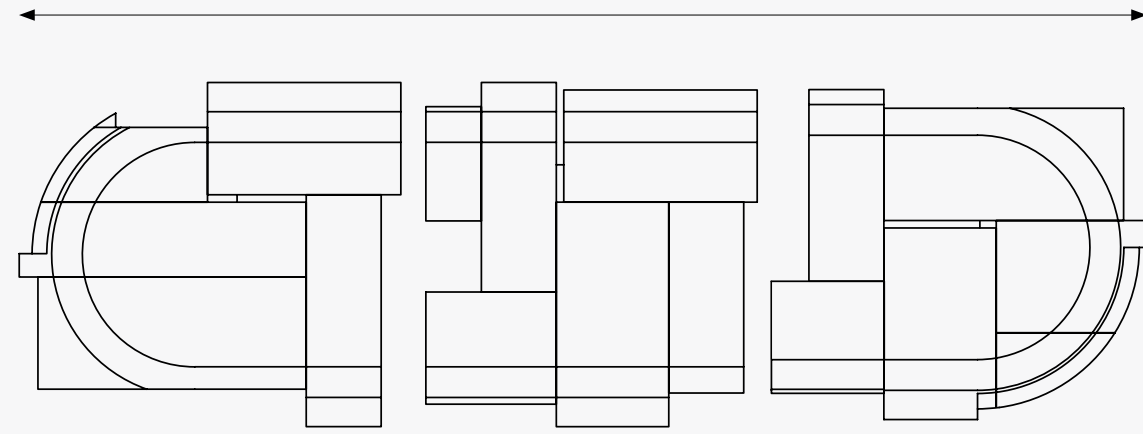

40

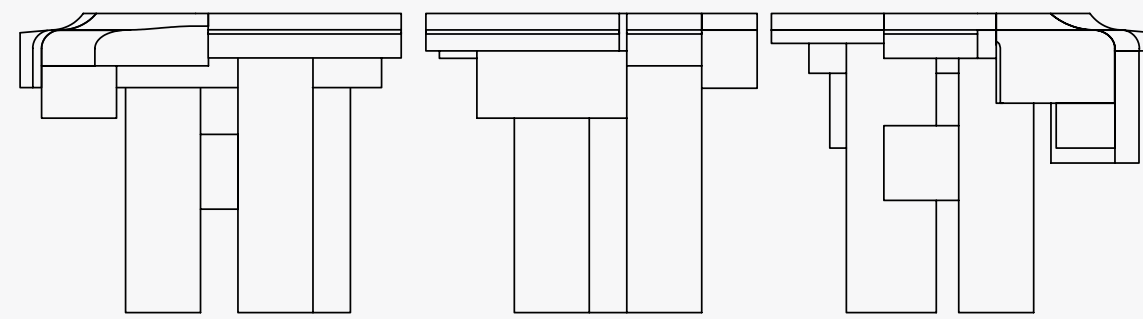

46

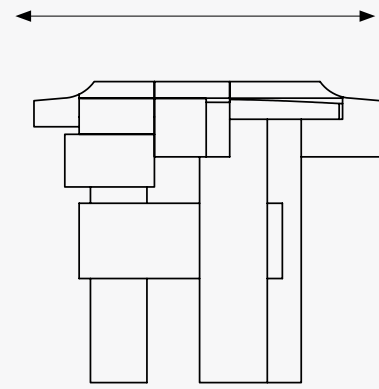

Agglomerati



Surfaced

[02]

Surfaced:
Coffee Table
Bianco Carrara

W	L	H	
135	137.5	30	cm
53.2	54.1	11.8	in

135

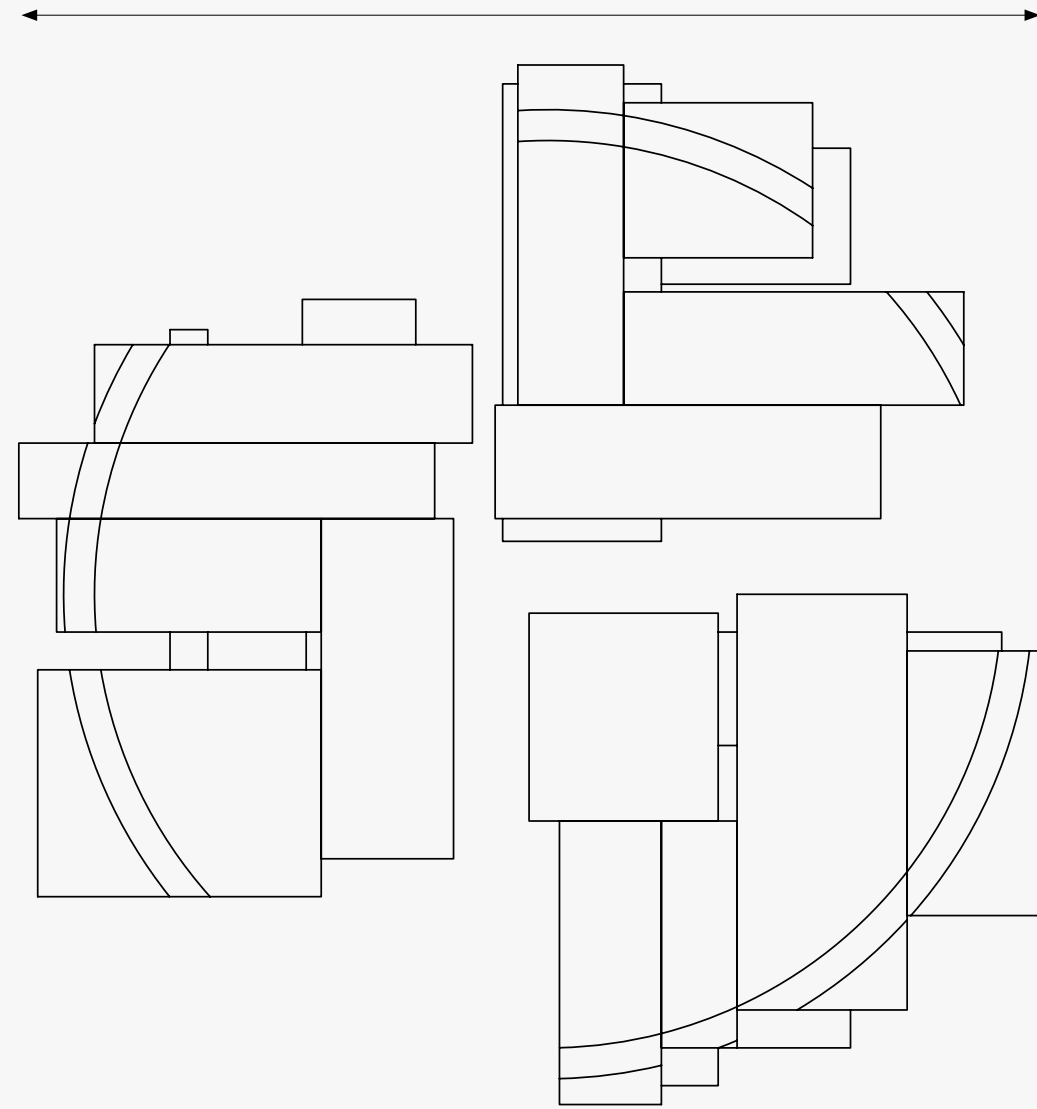

30

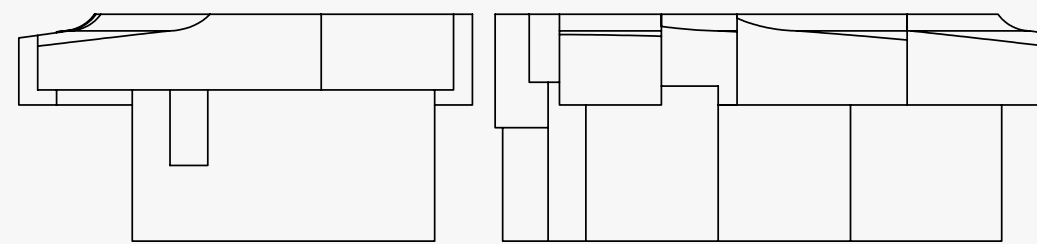

137.5

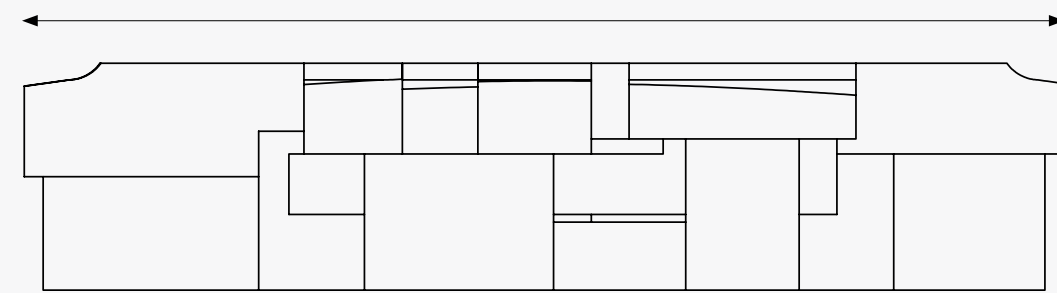

Agglomerati



Surfaced

[03]

Surfaced:
Side Table
Bianco Carrara

W L H
50 32.5 45 cm
19.7 12.8 17.7 in

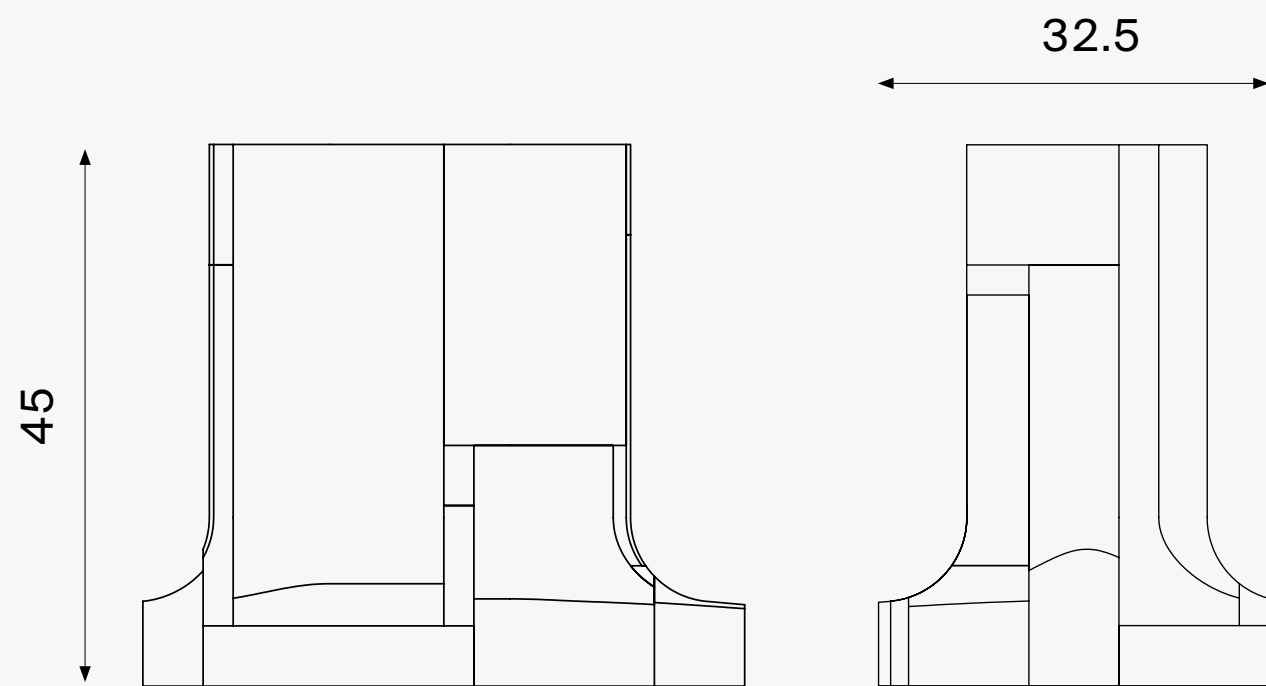
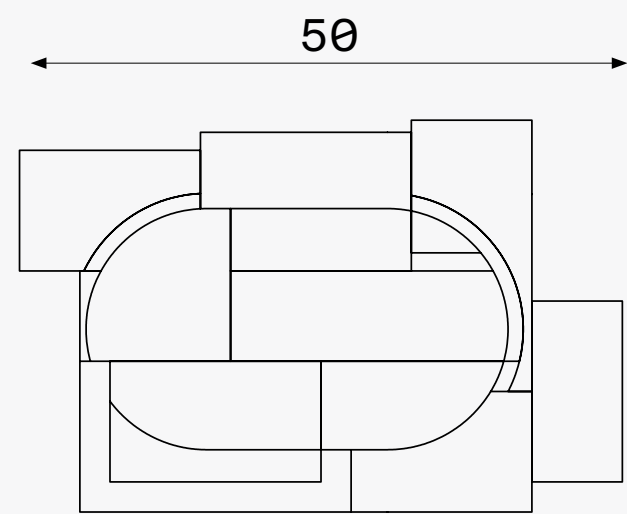

Agglomerati



Surfaced

Surfaced

Designer: Sho Ota
Production: Limited Edition
Typical lead time: 8 Weeks
Made in Italy

Materials

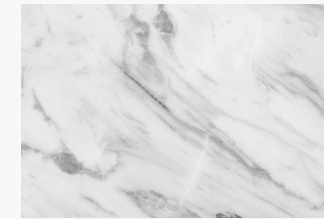

Bianco Carrara

The original Surfaced collection is crafted in Bianco Carrara, a timeless and monolithic marble that enhances its design.

The series is open to commissions, offering various object types, configurations, and unique stone options.

Agglomerati



[01] Surfaced
Bench
Bianco Carrara

W	L	H	
165	46	40	cm
65	18.1	15.7	in

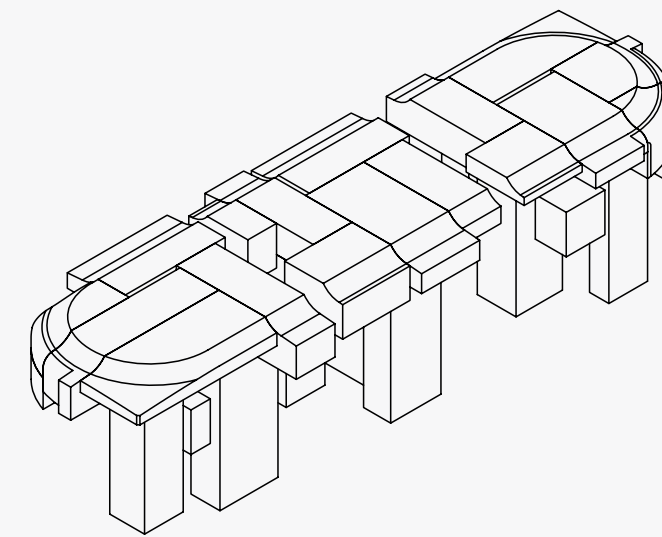

[02] Surfaced
Coffee Table
Bianco Carrara

W	L	H	
135	137.5	30	cm
53.2	54.1	11.8	in

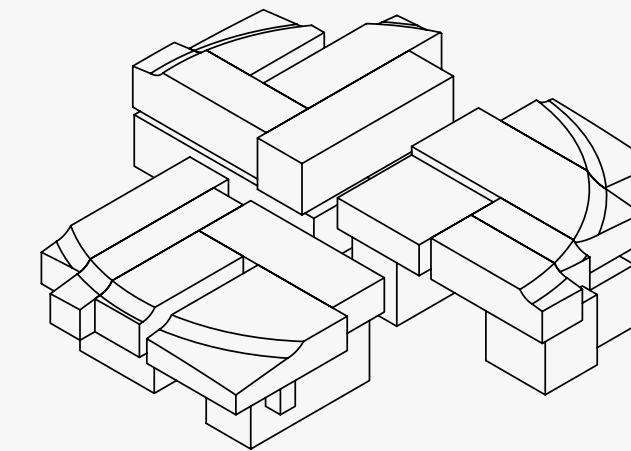

[03] Surfaced
Side Table
Bianco Carrara

W	L	H	
50	32.5	45	cm
19.7	12.8	17.7	in

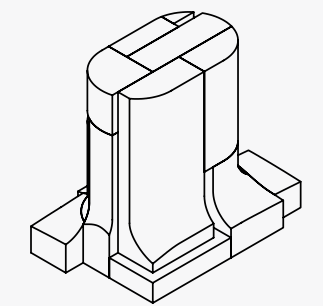

Surfaced

Agglomerati

Sho Ota

Sho Ota, originally from Japan and now based in the Netherlands, blends production and craftsmanship seamlessly. After six years designing wooden furniture in Japan, Ota pursued further studies in design, earning a master's degree from

the Design Academy Eindhoven's Contextual Design Department in 2018. He then established his own studio in Eindhoven, where he continues to create collectible, unique designs, free from the constraints of mass production.

Objects of Permanence

Agglomerati collaborates with multidisciplinary designers to create functional art-objects in stone.

Founded by Sam Henley, the studio connects a diverse network of creatives with northern Italy's foremost craftspeople, offering fresh perspectives on a time-honored material. The resulting bespoke objects are produced in collectible editions, adding a new material dimension to the collaborating artist's body of work. Each piece is crafted by Agglomerati's network of established

practitioners, using the finest materials and finished to the highest standards.

Translated from Italian, Agglomerati means "to mass together" or "a collection of things." This refers to the composition of minerals that, when placed under pressure over time, react to form stone. It also reflects the studio's evolving collective of creatives—individuals who come together to produce works made exclusively in stone.

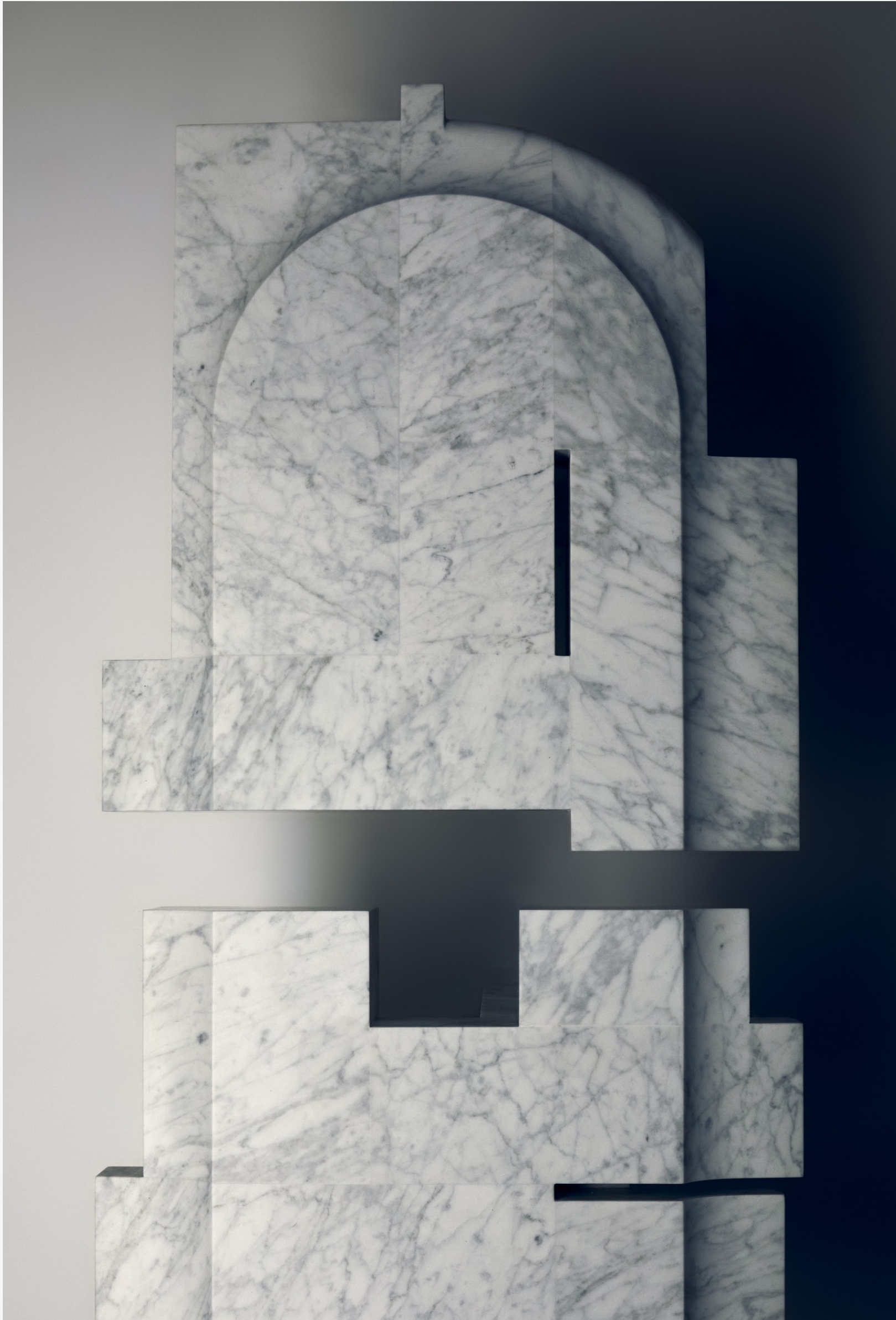

Agglomerati



Surfaced



Agglomerati

Contact

E info@agglomerati.com

T 0044 7513 703391

W agglomerati.com

IG [@agglomerati](https://www.instagram.com/agglomerati)