

Agglomerati

Cor

Designed by Tom Fereday

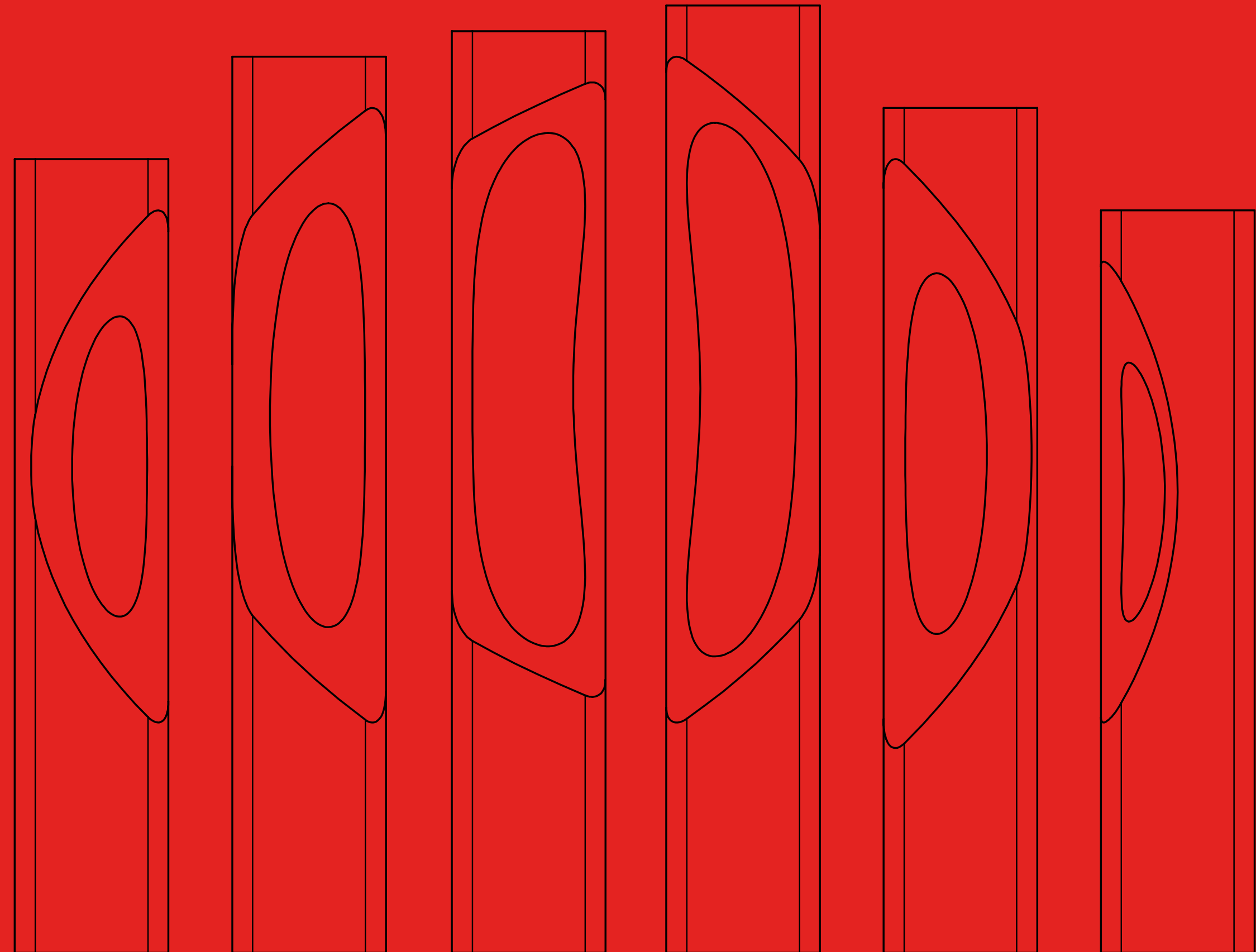

Cor

Cor is a series of towering, illuminated sculptures, each one exuding a gravity that speaks to the fundamental nature of stone.

Named after the Latin word for 'heart', Cor alludes to Earth as an organism, taking form through a series of luminous dissections of the porous surface, revealing a life source within.

The collection comprises a series of monolithic totems unique in height and formed around a piercing, spherical aperture that binds the collection. This negative space opens variously in each iteration, adding to the vessels' enigmatic presence that glows radiantly when lit.

Crafted from Roman travertine sourced from Tivoli and produced in the renowned Italian marble region of Pietrasanta, each piece in this limited-edition series showcases intricate and innovative internal coring, demonstrating a synthesis of material innovation and natural stone machining on an impressive scale. The pitted and permeable formations of the stone's structure are revealed through a unique angled cut aligning the patination of the stone.

Agglomerati

Cor 30

Designed by Tom Fereday



[01]

Cor 30-145
Roman Travertine

W L H
30 30 145 cm
11.8 11.8 57 in

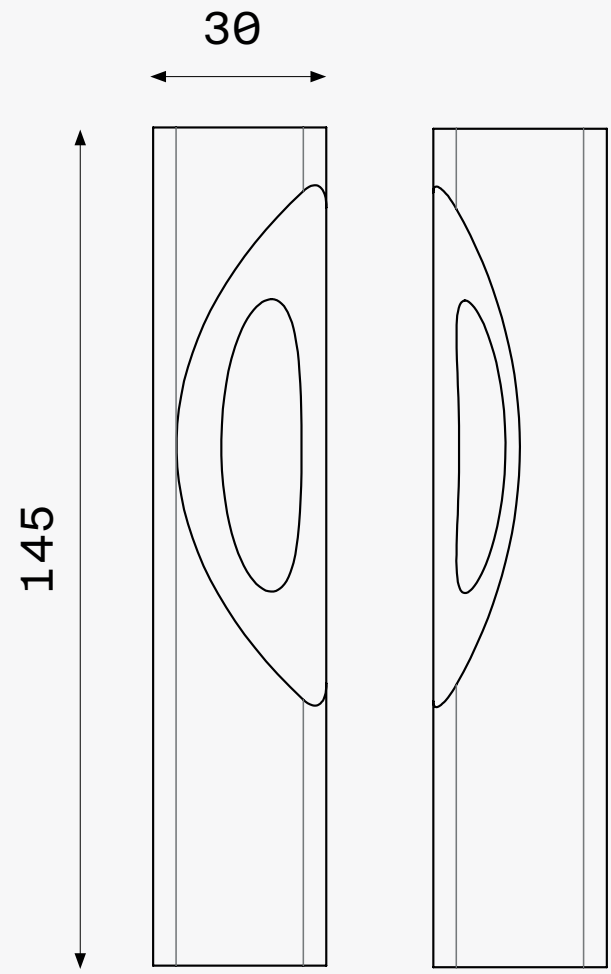
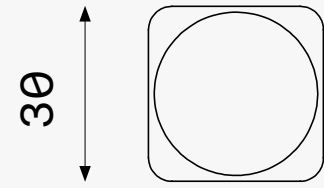

[02]

Cor 30-155
Roman Travertine

W L H
30 30 155 cm
11.8 11.8 61 in

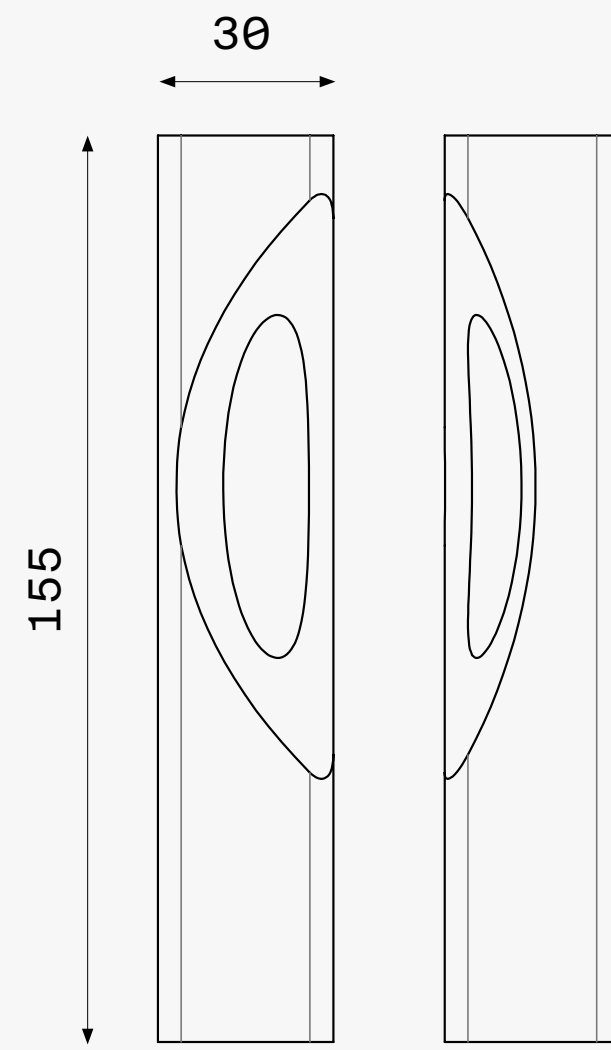
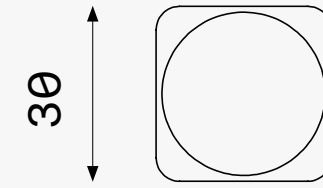

[03]

Cor 30-165
Roman Travertine

W L H
30 30 165 cm
11.8 11.8 65 in

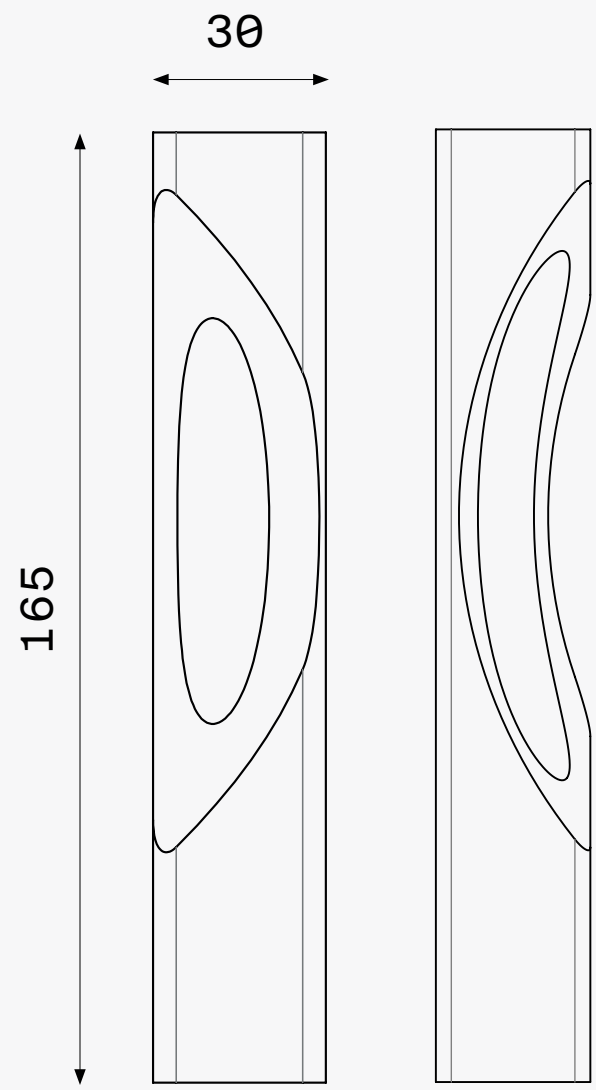
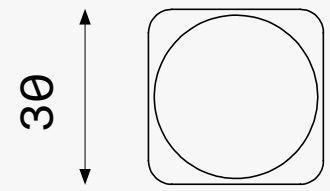

Agglomerati

[04]

Cor 30-175
Roman Travertine

W L H
30 30 175 cm
11.8 11.8 68.9 in

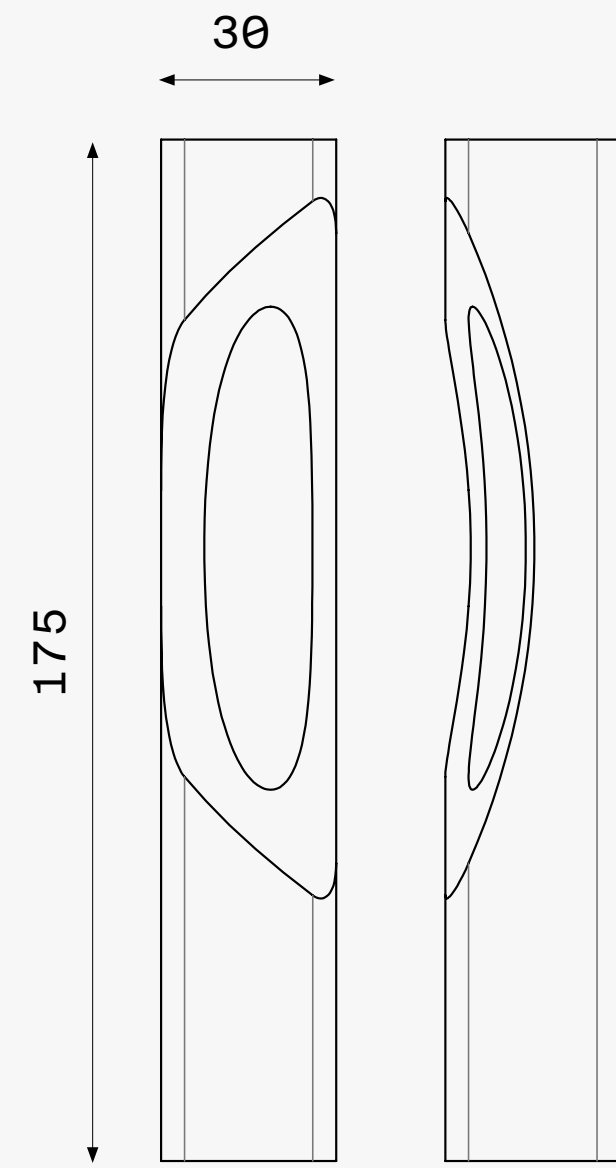
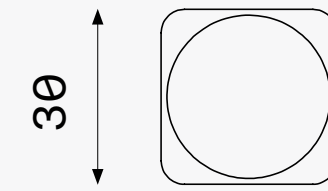

Cor

[05]

Cor 30-180
Roman Travertine

W L H
30 30 180 cm
11.8 11.8 70.8 in

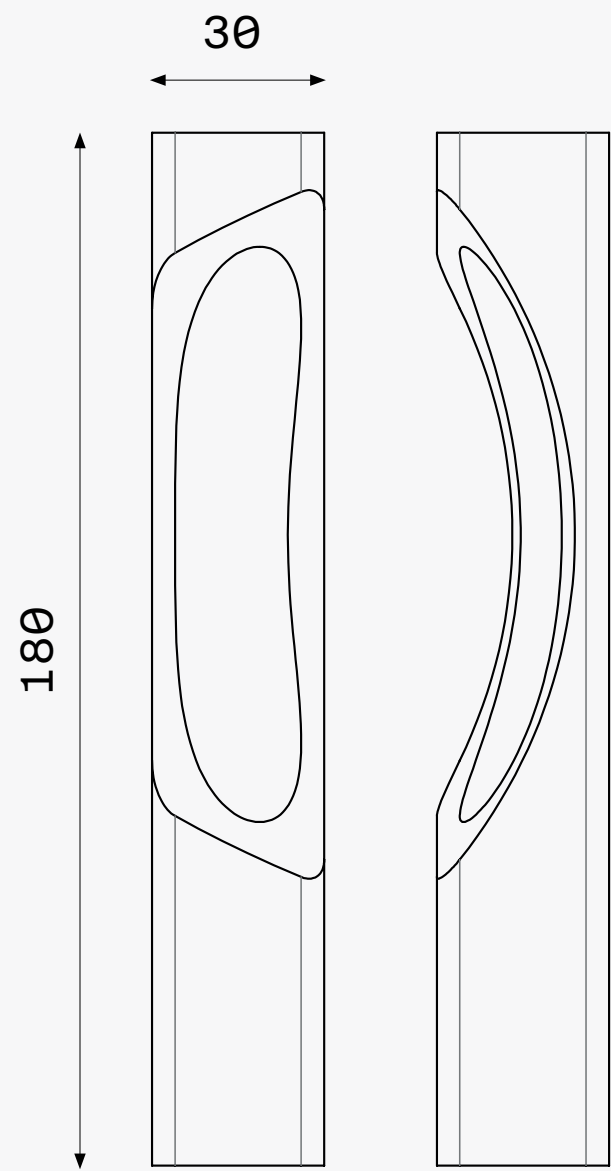
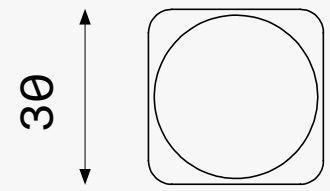

Agglomerati

[06]

Cor 30-185
Roman Travertine

W L H
30 30 185 cm
11.8 11.8 72.8 in

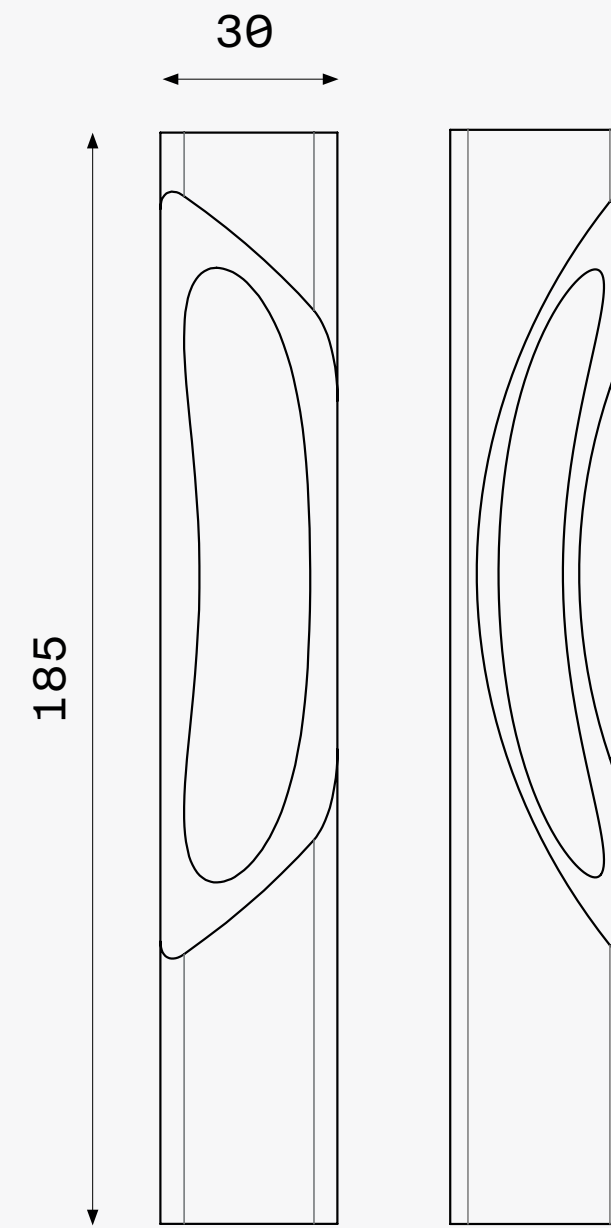
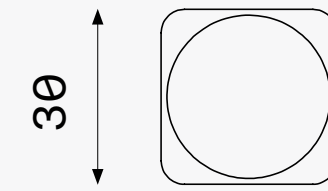

Cor

Cor 30

Designer: Tom Fereday
 Production: Open Series
 Typical lead time: 8 Weeks
 Made in Italy

Materials



Travertine
Classic

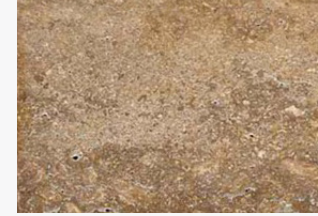

Travertine
Noce

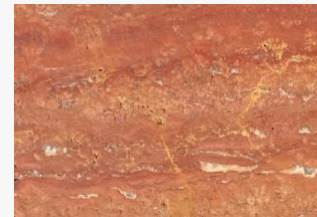

Travertine
Red

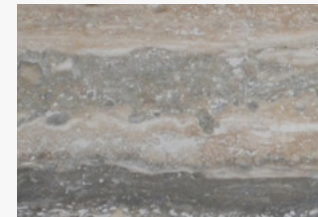

Travertine
Silver

Cor can be made in a variety of stone types upon request.

Dimmer

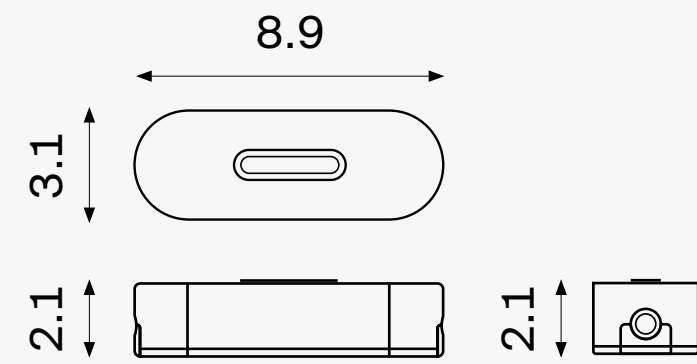

4-40W 120V | 4-60W 240V

Cord / Plug

The cord is supplied as standard at 3 meters, with plugs specified to the region. It is rated IP45 for waterproofing.

Other

All lighting fixtures and components are suitable for outdoor use and/or are IP45 rated for waterproofing, with the exception of the dimmer, which is not supplied in these instances.

Agglomerati

[01] Cor 30-145
Roman Travertine

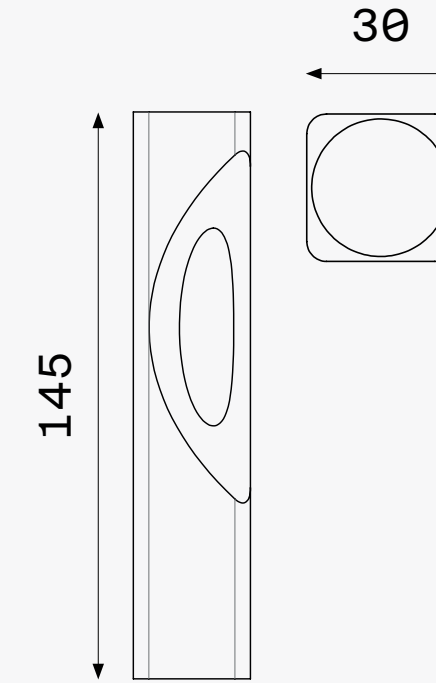

[02] Cor 30-155
Roman Travertine

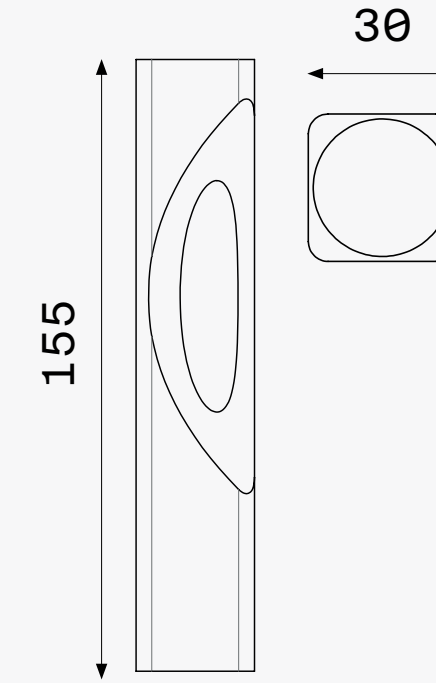

[03] Cor 30-165
Roman Travertine

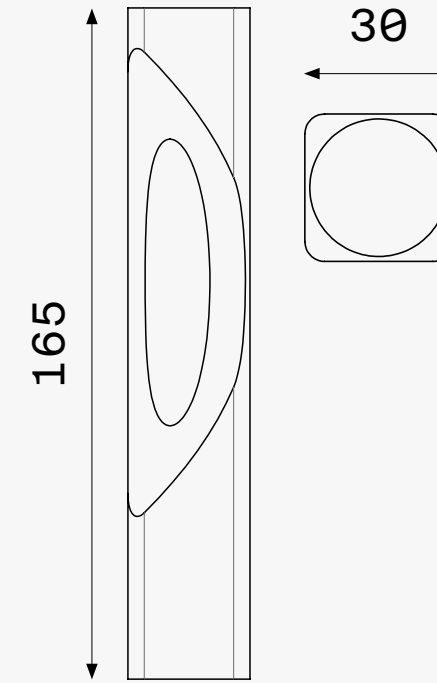

[04] Cor 30-175
Roman Travertine

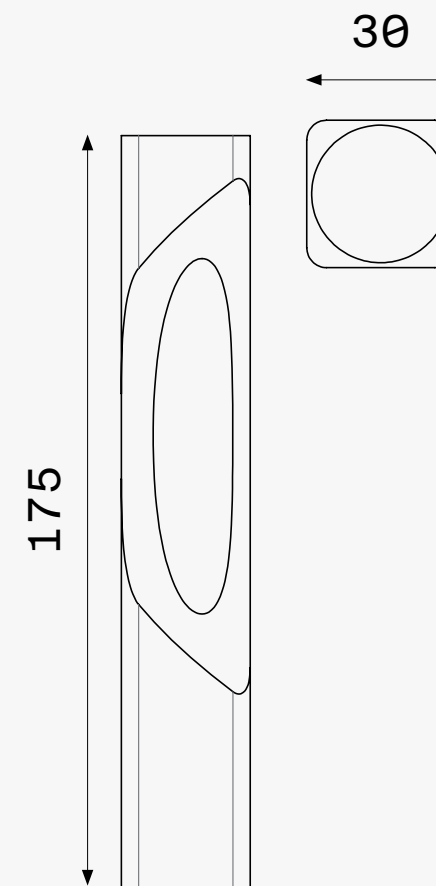

[05] Cor 30-180
Roman Travertine

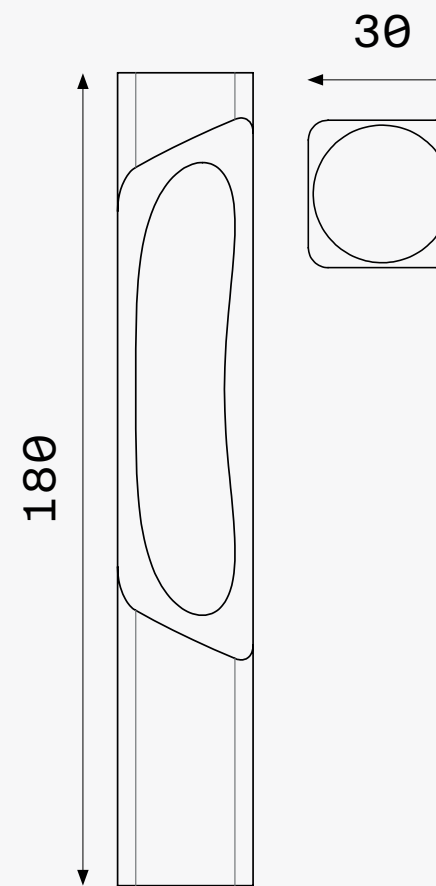

[06] Cor 30-185
Roman Travertine

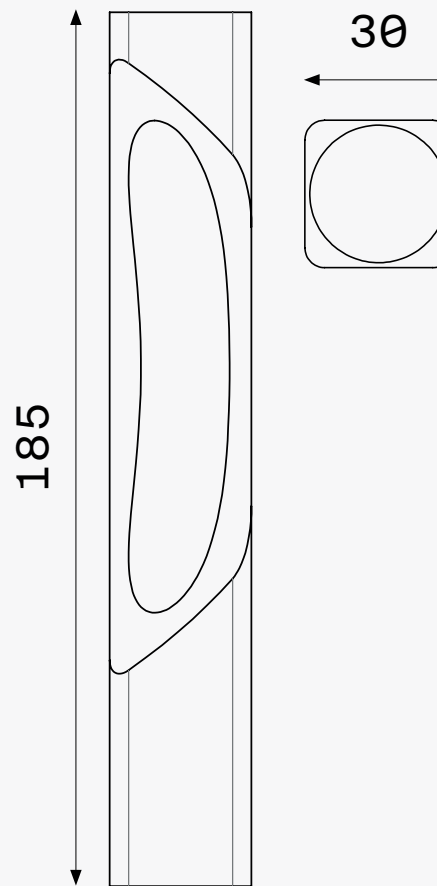

Cor

Agglomerati

Cor 20

Designed by Tom Fereday



[01]

Cor 20-100
Roman Travertine

W	L	H
20	20	100 cm
7.9	7.9	39.4 in

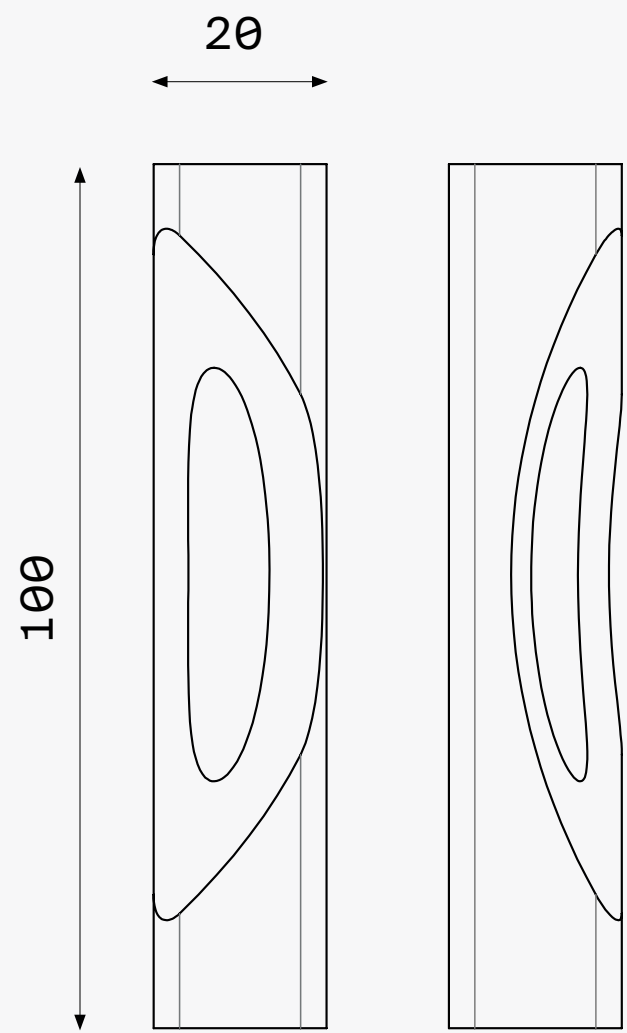
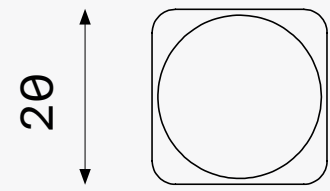

Agglomerati

[02]

Cor 20-119
Roman Travertine

W	L	H
20	20	119 cm
7.9	7.9	46.8 in

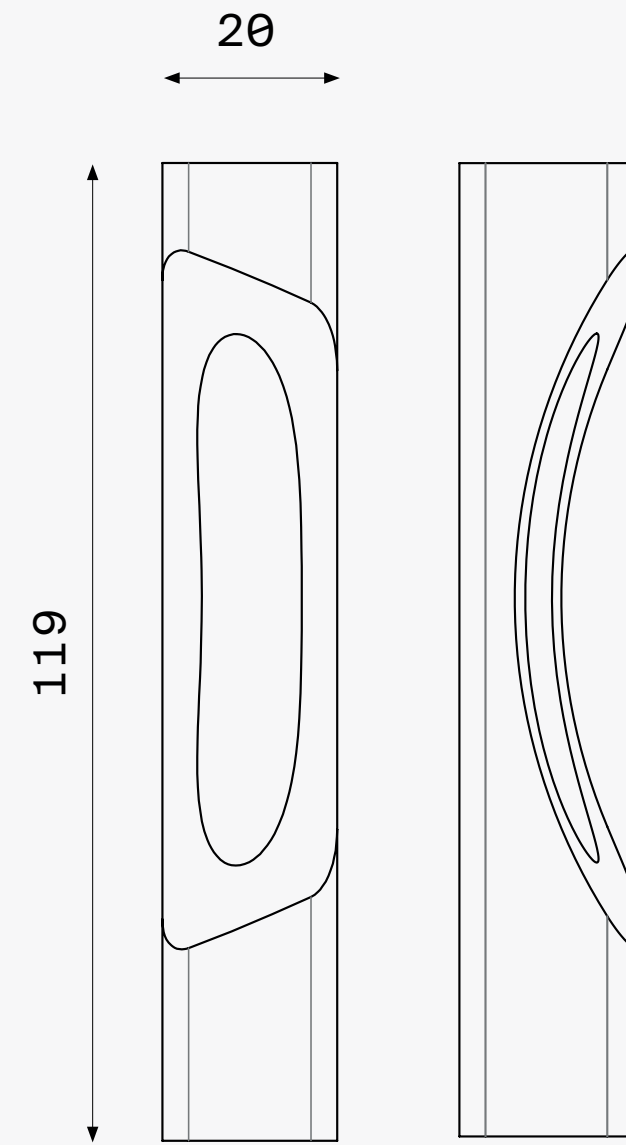
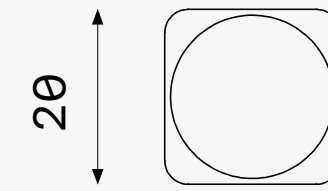

Cor

Cor 20

Designer: Tom Fereday
 Production: Open Series
 Typical lead time: 8 Weeks
 Made in Italy

Materials



Travertine
Classic

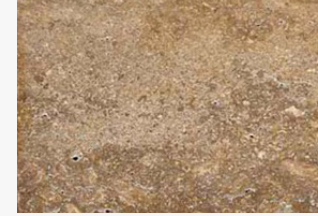

Travertine
Noce



Travertine
Red



Travertine
Silver

Cor can be made in a variety of stone types upon request.

Dimmer

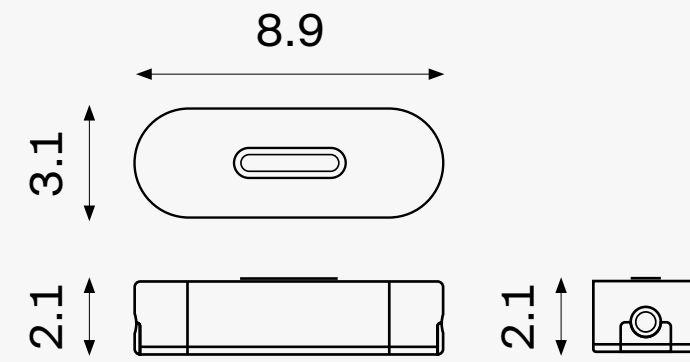

4-40W 120V | 4-60W 240V

Cord / Plug

The cord is supplied as standard at 3 meters, with plugs specified to the region. It is rated IP45 for waterproofing.

Other

All lighting fixtures and components are suitable for outdoor use and/or are IP45 rated for waterproofing, with the exception of the dimmer, which is not supplied in these instances.

Agglomerati

[01] Cor 20-100 Roman Travertine

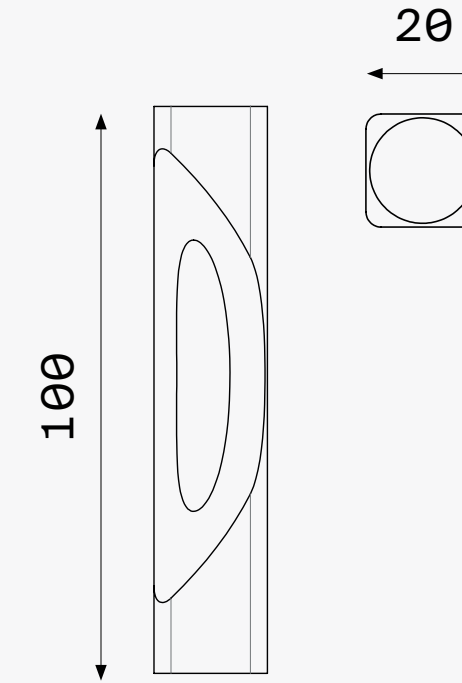

[02] Cor 20-119 Roman Travertine

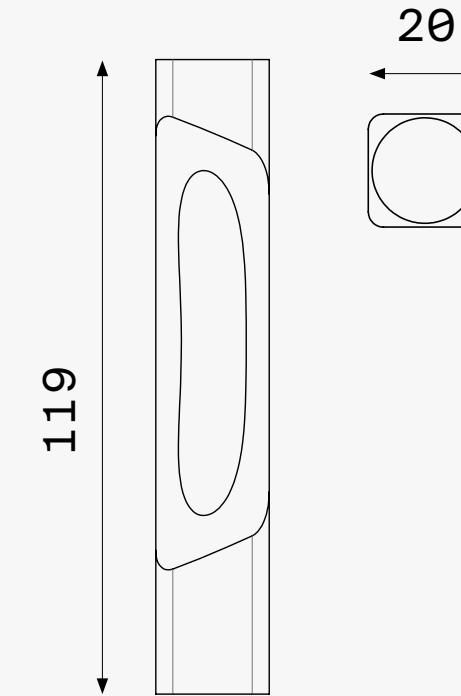

Cor

Agglomerati

Tom Fereday

Fascinated by the tension between natural materials and contemporary design and manufacturing, Australian designer Tom Fereday creates unique designs driven by an intrinsic inquiry into the role of objects today. Built on the principle of honest design, Fereday's work celebrates the materials and craftsmanship behind furniture and objects, leading to thoughtful and considered design outcomes that explore the idea of quiet innovation.

Taking a holistic approach, Fereday collaborates with renowned makers, designers, and brands, believing that through collaboration, more meaningful and resonant results can be achieved. His work spans furniture, product design, and lighting, with the inherent belief that technical construction, form, and exhibition should be considered as one.

Objects of Permanence

Agglomerati collaborates with multidisciplinary designers to create functional art-objects in stone.

Founded by Sam Henley, the studio connects a diverse network of creatives with northern Italy's foremost craftspeople, offering fresh perspectives on a time-honored material. The resulting bespoke objects are produced in collectible editions, adding a new material dimension to the collaborating artist's body of work. Each piece is crafted by Agglomerati's network of established

practitioners, using the finest materials and finished to the highest standards.

Translated from Italian, Agglomerati means "to mass together" or "a collection of things." This refers to the composition of minerals that, when placed under pressure over time, react to form stone. It also reflects the studio's evolving collective of creatives—individuals who come together to produce works made exclusively in stone.



Agglomerati

Cor

Agglomerati

Contact

E info@agglomerati.com

T 0044 7513 703391

W agglomerati.com

IG [@agglomerati](https://www.instagram.com/agglomerati)