

# Agglomerati

**Sekka**

Designed by Tino Seubert

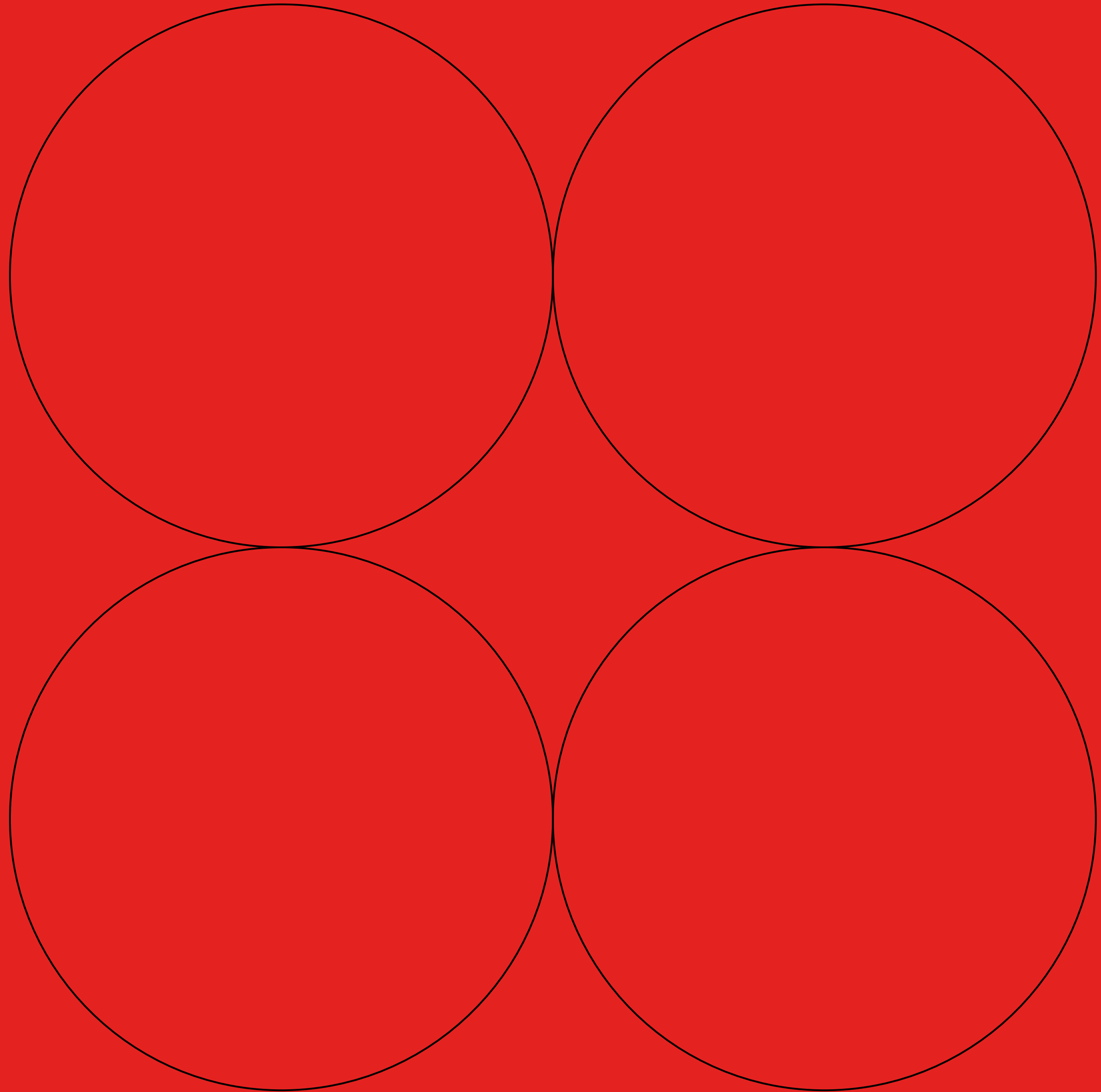

# Sekka

“Sekka” (雪花) in Japanese means “snowflake.” The word is composed of two kanji characters: 雪 (yuki), which means “snow,” and 花 (hana), which means “flower.”

Evolving from Tino Seubert's wooden Hana table series based on the flower motif, The Sekka table collection is conceived from a dialogue between material and concept. This progression of technique is captured and immortalised in marble, with the designer's signature details delicately frozen in noble stone.

Drawing influences from both Japanese carpentry and monolithic Mediterranean architecture, the Sekka collection is a testament to enduring design and

cross-cultural aesthetics. At its heart are five quintessential Italian marbles, each colour either contrasting or complementing the other as a four-pillared stem or tabletop.

Comprising round and rectangular side, coffee, and dining tables, the pieces are configured through the interplay of stone pairings, introducing a harmonious nuance that articulates the geometric detailing of the central flower motif.

# Agglomerati

## Sekka

Designed by Tino Seubert



Agglomerati

Sekka

# [01]

Sekka Side Round  
Verdi Alpi  
Bianco Carrara

W H  
50 45 cm  
19.7 17.7 in

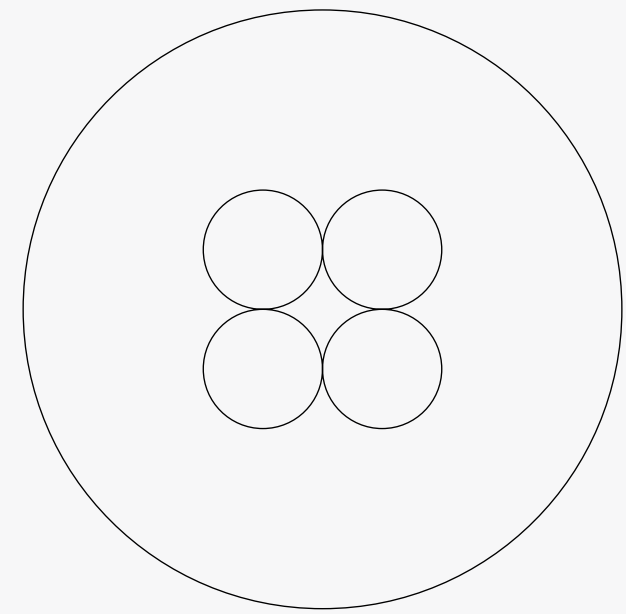

50

45

Agglomerati

# [02]

Sekka Side Rectangle  
Rosso Lepanto  
Jolie Grey

W L H  
42 50 45 cm  
16.5 19.7 17.7 in

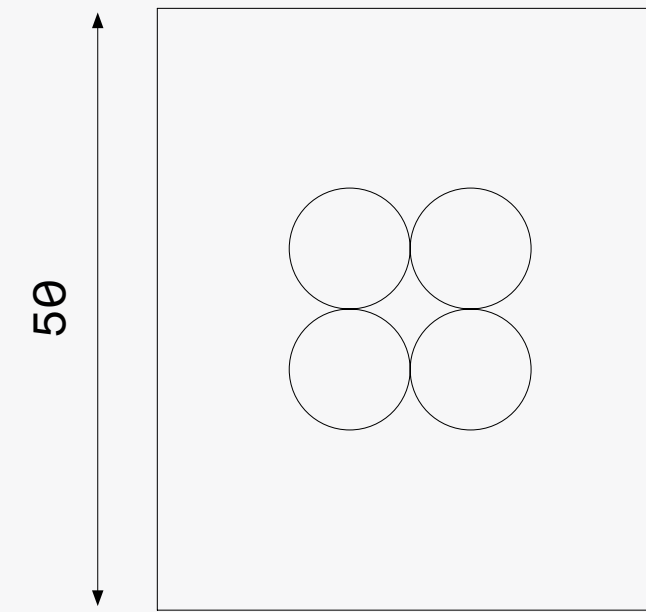

50

42

45

Sekka

# [03]

Sekka Coffee Round  
Bianco Carrara  
Jolie Grey

W H  
110 33 cm  
43.3 13 in



Agglomerati

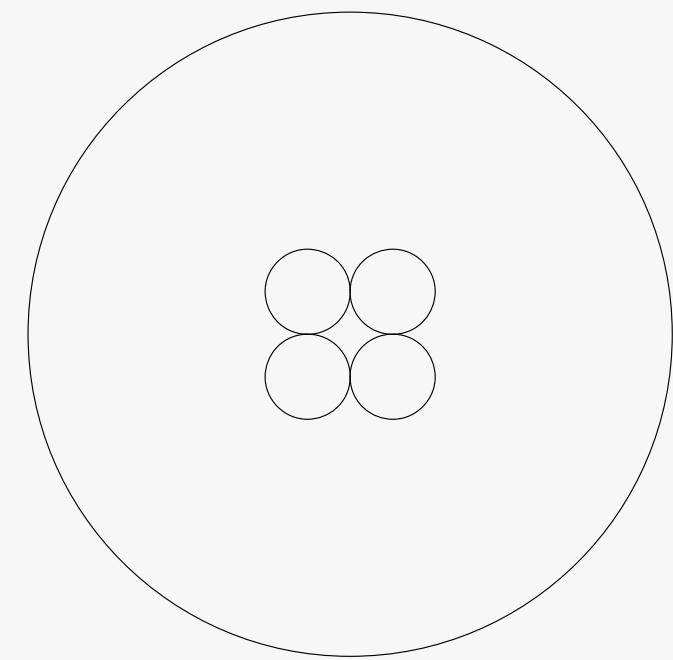

110

33

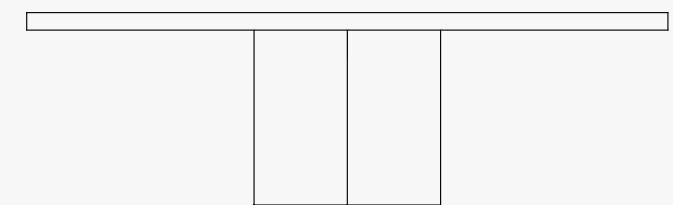

# [04]

Sekka Coffee Rectangle  
Verdi Alpi  
Rosso Lepanto

W L H  
90 110 33 cm  
35.4 43.3 13 in

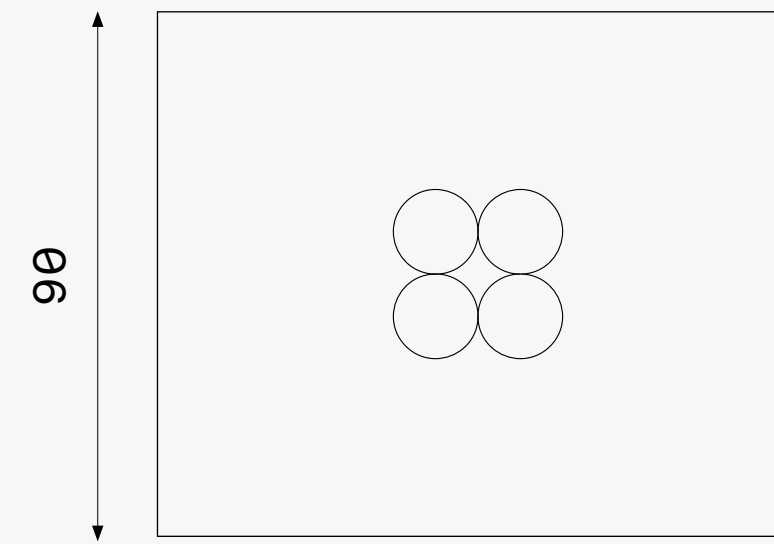
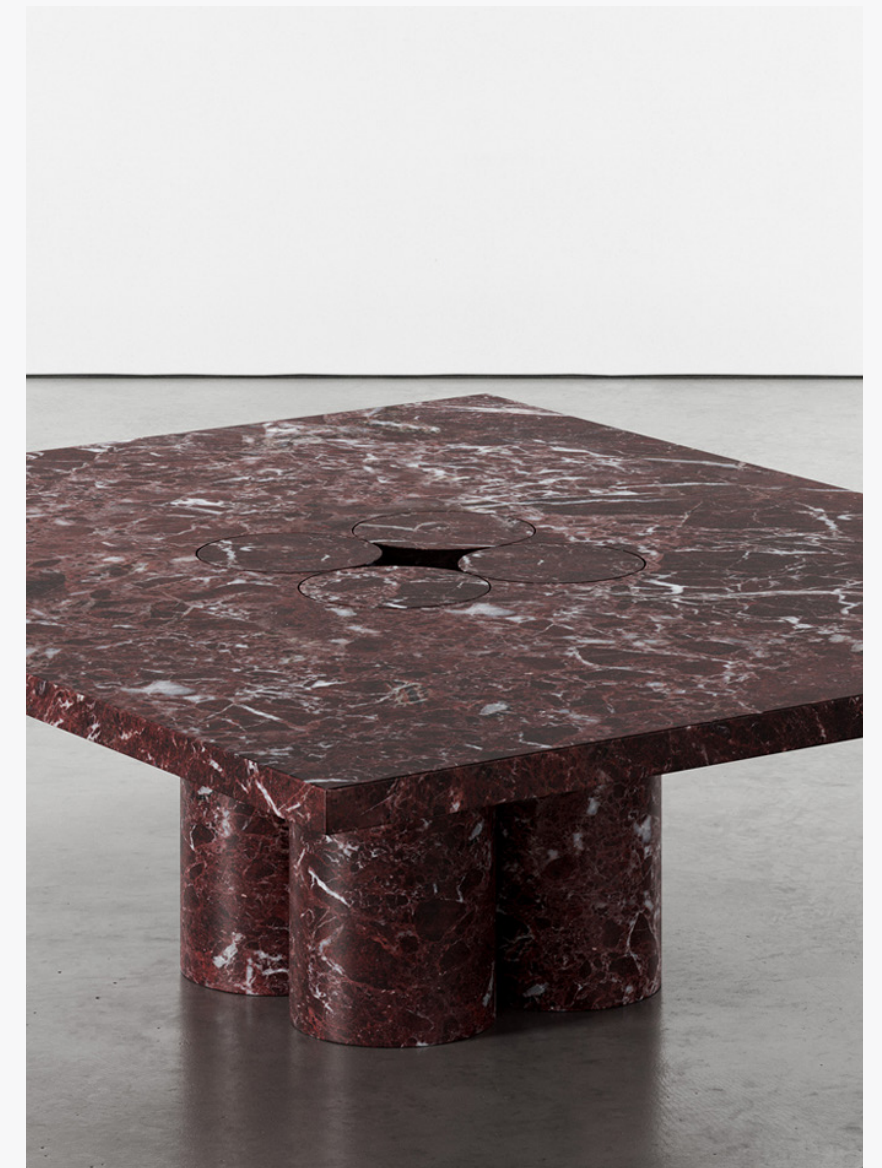

90

110

33

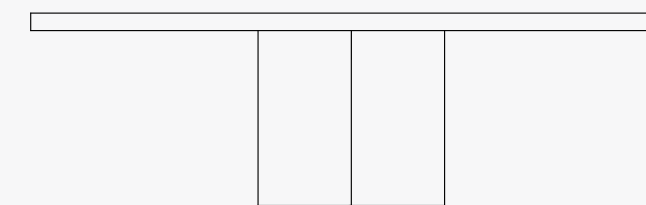

Sekka

# [05]

Sekka Dining Round  
Rosso Lepanto  
Bianco Carrara

W H  
140 75 cm  
55.1 29.5 in

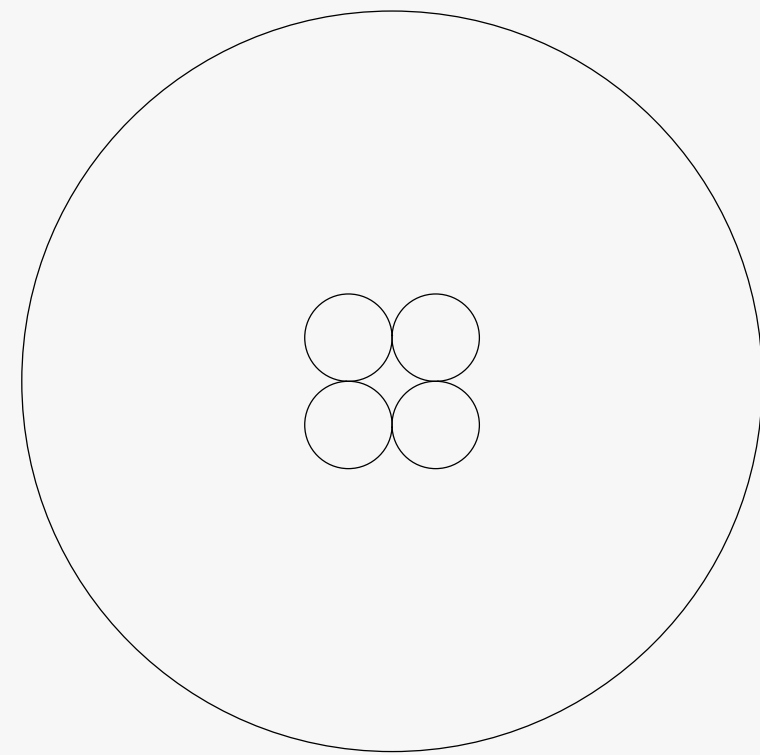

140

75

Agglomerati

# [06]

Sekka Dining Rectangle  
Jolie Grey  
Bianco Carrara

W L H  
42 50 45 cm  
16.5 19.7 17.7 in

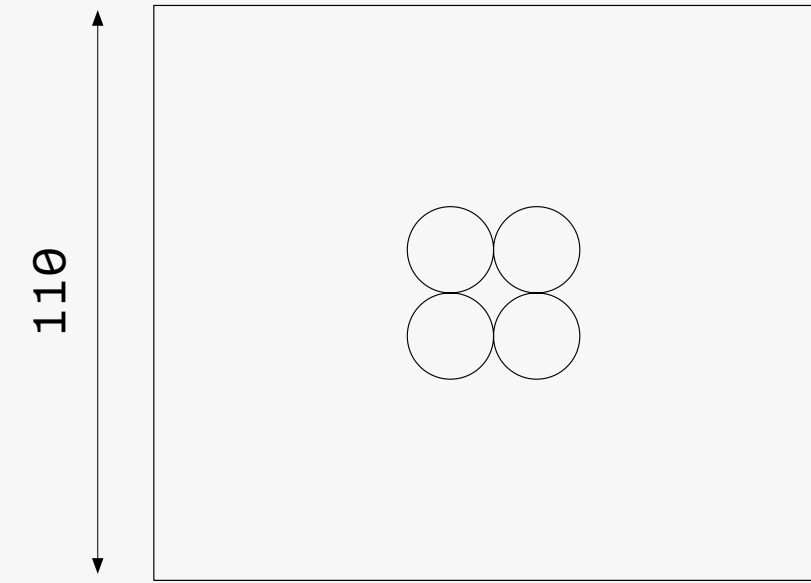

110

130

75

Sekka

# Sekka

## Materials

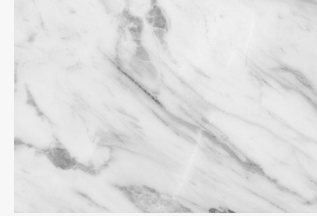

Bianco Carrara

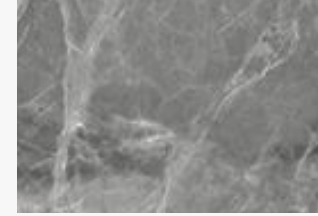

Jolie Grey

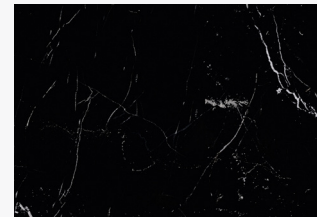

Nero Marquina

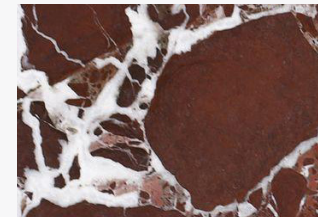

Rosso Lepanto

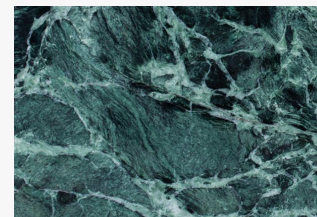

Verdi Alpi

## Stone pairings

The Sekka collection features an interplay of stone pairings. Choose from five varieties to create unique combinations, or opt to match the base and tabletop for a cohesive look.

Sekka can also be crafted from other stone varieties and customised in size to suit your project upon request.

Agglomerati

Designer: Tino Seubert  
 Production: Open Series  
 Typical lead time: 6-8 Weeks  
 Made in Italy

Please contact for price list  
[info@agglomerarti.com](mailto:info@agglomerarti.com)

**[01]** Sekka Side Round

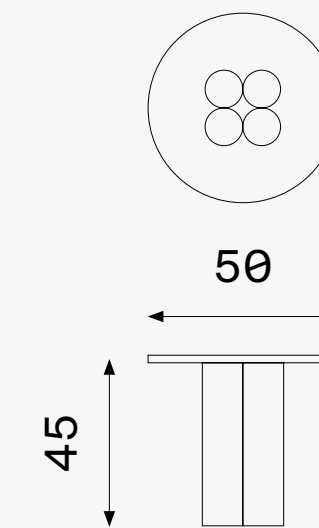

**[02]** Sekka Side Rectangle

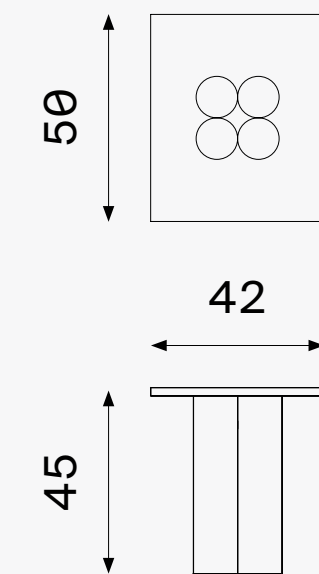

Sekka

**[03]** Sekka Coffee Round

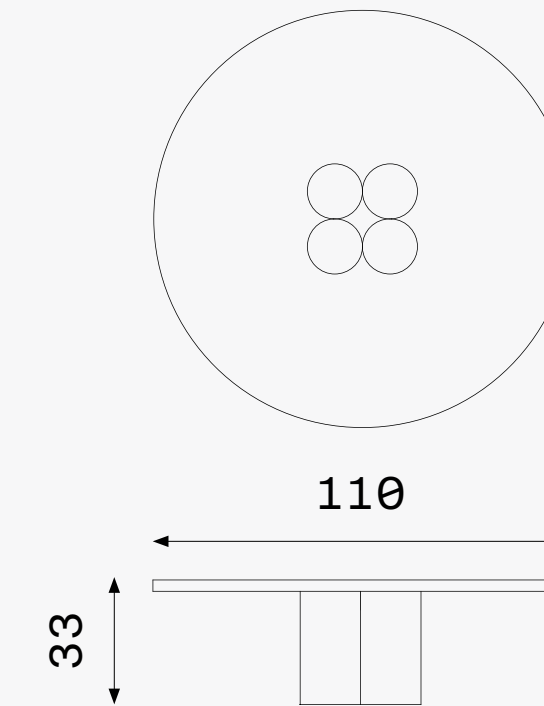

**[04]** Sekka Coffee Rectangle

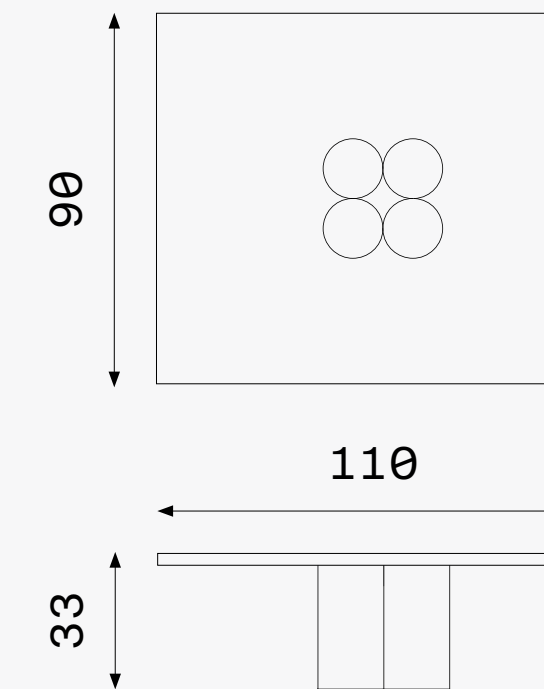

**[05]** Sekka Dining Round

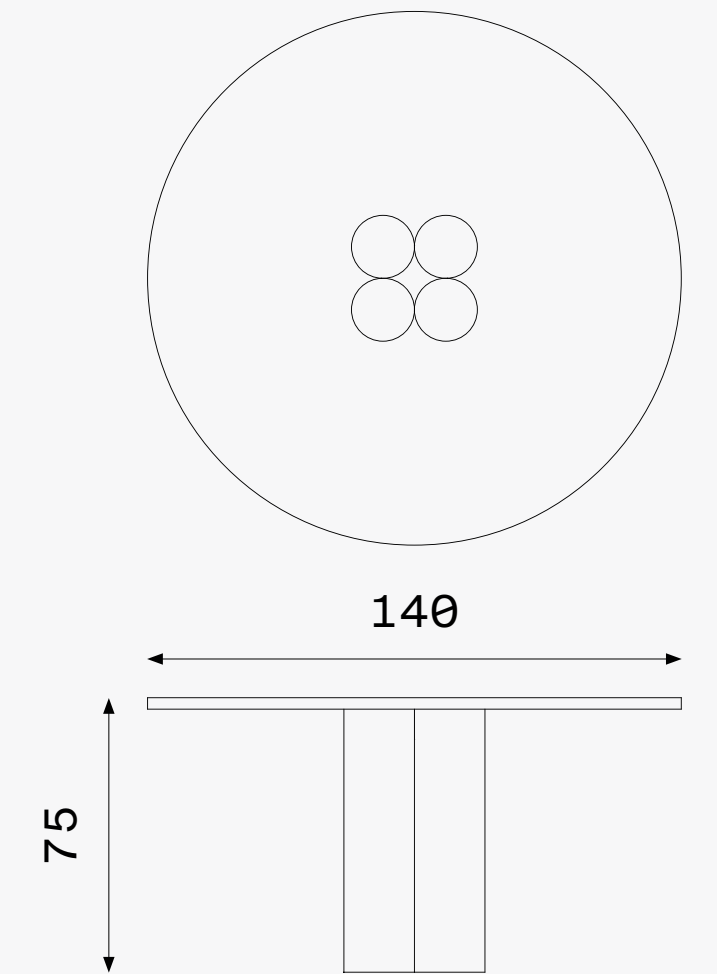

**[06]** Sekka Dining Rectangle

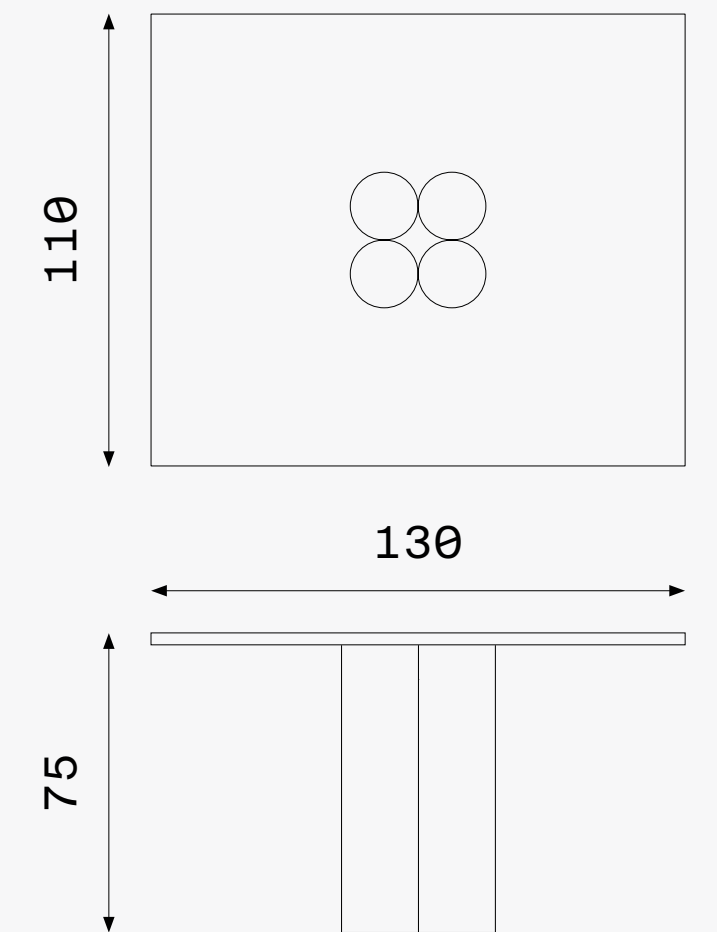

# Agglomerati

## Tino Seubert

Tino Seubert is a product designer based in London who revels in the juxtaposition of the organic and the industrial and enjoys the exploration of unconventional contexts.

For Seubert, the organic is often a welcoming entry point into his work, with people from different countries drawn in by familiar traditional craft elements, only to be tan-

talised by the clash with sleek, precise industrial design. As a designer, he thrives off energetic participation in the processes that go into making his pieces: whether it's wood and stonework or metal machining, electronics or anodising aluminium by hand, Seubert is always obsessively engaged with the details of his creations.

## Objects of Permanence

Agglomerati collaborates with multidisciplinary designers to create functional art-objects in stone.

Founded by Sam Henley, the studio connects a diverse network of creatives with northern Italy's foremost craftspeople, offering fresh perspectives on a time-honored material. The resulting bespoke objects are produced in collectible editions, adding a new material dimension to the collaborating artist's body of work. Each piece is crafted by Agglomerati's network of established

practitioners, using the finest materials and finished to the highest standards.

Translated from Italian, Agglomerati means "to mass together" or "a collection of things." This refers to the composition of minerals that, when placed under pressure over time, react to form stone. It also reflects the studio's evolving collective of creatives—individuals who come together to produce works made exclusively in stone.





Agglomerati

Sekka

# Agglomerati

## Contact

E [info@agglomerati.com](mailto:info@agglomerati.com)

T 0044 7513 703391

W [agglomerati.com](http://agglomerati.com)

IG [@agglomerati](https://www.instagram.com/agglomerati)